



ZEPHYR®
SCREWDRIVING TOOLS



Since 1938 Zephyr has served aerospace and industry with high quality, technically innovative tools produced in a manufacturing environment featuring intense quality control and superior customer service. Today more than ever Zephyr is carrying on this tradition of technical superiority coupled with outstanding quality and service. This catalog is one more example of Zephyr quality and service. It is specially designed and edited to make selection and ordering easy.



ZEPHYR PART NUMBERS— your guide to quality and hardness

Only Zephyr of all major screwdriver bit manufacturers gives you a complete part number on the bit to assure that you have the right bit you need for the job.

Use "X" grade for hard sheet metal screws and fasteners. "A" grade is recommended for machine screws.

"I" Intermediate hardness is also available on order.

All Zephyr bits are heat treated in small lots for consistent quality. Zephyr's unique Z-Forge™ process assures exact dimensional fit in the recess. **A Zephyr bit gives the truest fit, longest performance and with our new ACR® bits, the least cam-out and product damage of any available at any price.**

Made in U.S.A.

Every Zephyr bit proudly wears this mark. We assure you that we will always supply the finest product engineered to last.

Safety Counts

Zephyr products are designed to be safe under proper working conditions. Be sure that you know the proper way to use a tool before working with it. We recommend the wearing of eye protection when using any hand tool or machine shop tool.

Keep your tools clean, inspect them from time to time, and replace worn or damaged tools. The nominal cost will be more than offset by the reduction in mistakes and the savings on rework.

Made to order specials available on request.

**FOR MORE ON ZEPHYR QUALITY AND INNOVATION
SEE CENTER INSERT.**

This catalog contains screwdriving tools to fit these screw heads:



ACR®-Phillips
and Phillips
page 2-3-4



Slotted
page 5



ACR®-Pozidriv®
and Pozidriv®
page 6



French Recess
page 7



Hex Socket
page 7-8



Hex Tamper
Resistant
page 8



Square Recess
page 8-9



Torx®
page 9-10



Torx® Tamper
Resistant
page 9-10



Torx Plus®
page 11



Spanner
page 11



Torq-Set®-ACR®
and Torq-Set®
page 11-12-13



Tri-Wing®-ACR®
and Tri-Wing®
page 14-15-16



Hi-Torque®
page 16



*Clutch



*Frearson



*Supadriv®

ACR®, Torq-Set®, Torq-Set®-ACR®, Tri-Wing®, Tri-Wing®-ACR®, and Pozidriv® are registered trademarks of the Phillips Screw Company. Torx® and TorxPlus® are registered trademarks of the Camcar Division of Textron. Supadriv® is a registered trademark of European Industrial Services (Fasteners) Limited. ZEPHYR® is a registered trademark of Zephyr Manufacturing Co., Inc.

*Items not in this catalog, available on request.







NOTE: Desoutter and Yankee type drives available on request.

TABLE OF CONTENTS

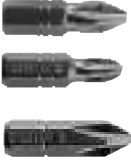
	PAGE	
INSERT AND POWER BITS		
ACR®-Phillips	2/3	
Phillips	3/4	
Slotted	5	
ACR®-Pozidriv®	6	
Pozidriv®	6	
French Recess (B.N.A.E.)	7	
Socket (Allen) Head - Standard and Tamper Resistant	7/8	
Square Recess	8/9	
Torx® - Standard and Tamper Resistant	9/10	
Torx Plus®	11	
Spanner - Tamper Resistant	11	
Torq-Set®-ACR®	11/12	
Torq-Set®	12/13	
Tri-wing®-ACR®	14	
Tri-wing®	15/16	
Hi-Torque®	16	
INSERT BIT HOLDERS		
Hex Shank to Female Hex	17	
Threaded Drive to Female Hex	17	
Female Square Drive to Female Hex or Square	18	
NUT SETTERS		
Hex Shank Drive to Female Hex	19	
Metric Hex Shank Drive to Female Hex	19	
SQUARE DRIVE SOCKETS (FOR HEX SCREWS OR NUTS)		
1/4" Square Drive	20	
3/8" Square Drive	21	
1/2" Square Drive	21	
1/4" Reversible Drive	21	
EXTENSIONS		
Hex Shank Drive to Male Square	22	
Hex Shank to Male Hex (Reversible)	22	
HAND BIT HOLDERS (MAGNETIC OR NON-MAGNETIC)		
Combination Holder with Bit Storage	23	
Stubby Holder with Solid Handle	23	
Solid Handle	23	
HAND SCREWDRIVERS		
ACR®-Phillips	24	
Pozidriv®	24	
Torq-Set®	25	
Tri-wing®	25	
NATIONAL STOCK NUMBER TO ZEPHYR PART NUMBER		26
TABLE OF SCREW SIZES		INSIDE BACK COVER
Phillips		
Slotted		

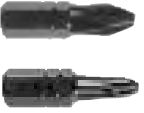



ACR®-PHILLIPS INSERT BITS

	POINT SIZE	OVERALL LENGTH	PART NO. AIRCRAFT (Machine Screws)	PART NO. INDUSTRIAL (Self Tapping Screws)
1/4" hex shank ACR-B 4x4™ 	1	1"	D1221AAACR-B	D1221XXACR-B
	2	1"	D1222AAACR-B	D1222XXACR-B
	3	1"	D1223AAACR-B	D1223XXACR-B
Reduced Nose Drywall	2	1"	—	D1327XXACR-B
Milled Point	1	1"	D1221AMACR-B	—
	2	1"	D1222AMACR-B	—
1/4" hex shank installation 	1	1"	D1221AARI	D1221XXRI
	2	1"	D1222AARI	D1222XXRI
	3	1"	D1223AARI	D1223XXRI
Reduced Nose Diameter	2	1"	D1227AARI	D1227XXRI
	2	1 1/2"	D1227AA15RI	D1227XX15RI
	2	2"	D1227AA2RI	D1227XX2R
Drywall	2	1"	D1327AARI	D1327XXRI
1/4" hex shank removal 	1	1"	D1221AAR	D1221XXR
	2	1"	D1222AAR	D1222XXR
	3	1"	D1223AAR	D1223XXR
Reduced Nose Diameter	2	1"	D1227AAR	D1227XXR
	2	1 1/2"	D1227AA15R	D1227XX15R
	2	2"	D1227AA2R	D1227XX2R
Drywall	2	1"	D1327AAR	D1327XXR
5/16" hex shank ACR-B 4x4™ 	2	1 1/4"	D1232AAACR-B	—
	3	1 1/4"	D1233AAACR-B	—
	4	1 1/4"	D1234AAACR-B	—
5/16" hex shank installation 	1	1 1/4"	D1231AARI	D1231XXRI
	2	1 1/4"	D1232AARI	D1232XXRI
	3	1 1/4"	D1233AARI	D1233XXRI
5/16" hex shank removal 	1	1 1/4"	D1231AAR	D1231XXR
	2	1 1/4"	D1232AAR	D1232XXR
	3	1 1/4"	D1233AAR	D1233XXR

NOTE: When ordering one way ACR® Phillips bits specify "R" for removal and "RI" for installation.



ACR®-PHILLIPS POWER BITS

	BODY DIAMETER	POINT SIZE	OVERALL LENGTH	PART NO. AIRCRAFT (Machine Screws)	PART NO. INDUSTRIAL (Self Tapping Screws)
1/4" hex shank ACR-B 4x4™ 	3/16"	1	1 5/16"	—	E1101XXACR-B
	1/4"	2	1 5/16"	—	E1102XXACR-B
	1/4"	3	1 5/16"	—	E1103XXACR-B
Full Body Hex 		1	1 5/16"	—	E1541XXACR-B
		2	1 5/16"	—	E1542XXACR-B
		3	1 5/16"	—	E1543XXACR-B

ACR®-PHILLIPS POWER BITS (Continued)



BODY DIAMETER	POINT SIZE	OVERALL LENGTH	PART NO. AIRCRAFT (Machine Screws)	PART NO. INDUSTRIAL (Self Tapping Screws)	
3/16"	1	1 15/16"	E1101AARI	E1101XXRI	1/4" hex shank installation
1/4"	2	1 15/16"	E1102AARI	E1102XXRI	
1/4"	3	1 15/16"	E1103AARI	E1103XXRI	
3/16"	1	2 3/4"	E1101AA275RI	E1101XX275RI	
1/4"	2	2 3/4"	E1102AA275RI	E1102XX275RI	
1/4"	3	2 3/4"	E1103AA275RI	E1103XX275RI	
3/16"	1	3 1/2"	E1101AA35RI	E1101XX35RI	
1/4"	2	3 1/2"	E1102AA35RI	E1102XX35RI	
1/4"	3	3 1/2"	E1103AA35RI	E1103XX35RI	
3/16"	1	6"	E1101AA6RI	E1101XX6RI	
1/4"	2	6"	E1102AA6RI	E1102XX6RI	
1/4"	3	6"	E1103AA6RI	E1103XX6RI	
3/16"	1	1 15/16"	E1101AAR	E1101XXR	1/4" hex shank removal
1/4"	2	1 15/16"	E1102AAR	E1102XXR	
1/4"	3	1 15/16"	E1103AAR	E1103XXR	
3/16"	1	2 3/4"	E1101AA275R	E1101XX275R	
1/4"	2	2 3/4"	E1102AA275R	E1102XX275R	
1/4"	3	2 3/4"	E1103AA275R	E1103XX275R	
3/16"	1	3 1/2"	E1101AA35R	E1101XX35R	
1/4"	2	3 1/2"	E1102AA35R	E1102XX35R	
1/4"	3	3 1/2"	E1103AA35R	E1103XX35R	
3/16"	1	6"	E1101AA6R	E1101XX6R	
1/4"	2	6"	E1102AA6R	E1102XX6R	
1/4"	3	6"	E1103AA6R	E1103XX6R	



ACR® is a registered trademark of the Phillips Screw Company

Note: Information regarding screwdrivers with threaded shanks or in special lengths is available on request.

PHILLIPS INSERT BITS





POINT SIZE	OVERALL LENGTH	PART NO. AIRCRAFT (Machine Screws)	PART NO. INDUSTRIAL (Self Tapping Screws)	
0	1"	D1220AA	D1220XX	1/4" hex shank
1	1"	D1221AA	D1221XX	
1	1"	D1221AM*	D1221XM*	
1	1 1/2"	D1221AA15	D1221XX15	
1	2"	D1221AA2	D1221XX2	
2	1"	D1222AA	D1222XX	
2	1"	D1222AM*	D1222XM*	
2	1 1/2"	D1222AA15	D1222XX15	
2	2"	D1222AA2	D1222XX2	
2	2 1/2"	D1222AA25	D1222XX25	
3	1"	D1223AA	D1223XX	
3	1"	D1223AM*	D1223XM*	
4	1 1/4"	D1224AA	D1224XX	
4	1 1/4"	D1224AM*	D1224XM*	
2	1"	D1227AA	D1227XX	Reduced Nose Diameter
2	1 1/2"	D1227AA15	D1227XX15	
2	2"	D1227AA2	D1227XX2	
1	1"	D1228AA	D1228XX	
2	1"	D1327AA	D1327XX	Drywall
2	1"		P2R*	Reduced Nose Machined Point



*New special milled point.







PHILLIPS INSERT BITS (Continued)

	POINT SIZE	OVERALL LENGTH	PART NO. AIRCRAFT (Machine Screws)	PART NO. INDUSTRIAL (Self Tapping Screws)
	1	1 1/4"	D1231AA	D1231XX
	2	1 1/4"	D1232AA	D1232XX
	3	1 1/4"	D1233AA	D1233XX
	4	1 1/4"	D1234AA	D1234XX
	4	1 1/2"	D1234AA15	D1234XX15
	1	1"	D1241AA	D1241XX
	2	1"	D1242AA	D1242XX
	3	1"	D1243AA	D1243XX
	1	1 1/4"	D1251AA	D1251XX
	2	1 1/4"	D1252AA	D1252XX
	3	1 1/4"	D1253AA	D1253XX
	4	1 1/4"	D1254AA	D1254XX





PHILLIPS POWER BITS

	BODY DIAMETER	POINT SIZE	OVERALL LENGTH	PART NO. AIRCRAFT (Machine Screws)	PART NO. INDUSTRIAL (Self Tapping Screws)
	3/16"	0	1 15/16"	E1100AA	E1100XX
	3/16"	1	1 15/16"	E1101AA	E1101XX
	1/4"	2	1 15/16"	E1102AA	E1102XX
	1/4"	3	1 15/16"	E1103AA	E1103XX
	3/16"	1	2 3/4"	E1101AA275	E1101XX275
	1/4"	2	2 3/4"	E1102AA275	E1102XX275
	1/4"	3	2 3/4"	E1103AA275	E1103XX275
	3/16"	1	3 1/2"	E1101AA35	E1101XX35
	1/4"	2	3 1/2"	E1102AA35	E1102XX35
	1/4"	3	3 1/2"	E1103AA35	E1103XX35
	3/16"	1	6"	E1101AA6	E1101XX6
	1/4"	2	6"	E1102AA6	E1102XX6
	1/4"	3	6"	E1103AA6	E1103XX6
 Full Body Hex	1/4"	1	1 15/16"	—	E1541XX
	1/4"	2	1 15/16"	—	E1542XX
	1/4"	3	1 15/16"	—	E1543XX
	3/16"	1	3"	E1201AA	E1201XX
	1/4"	2	3"	E1202AA	E1202XX
	5/16"	3	3"	E1203AA	E1203XX
	5/16"	2	3 1/2"	E1092AA35	—
	5/16"	3	3 1/2"	E1093AA35	—
	5/16"	4	3 1/2"	E1094AA35	—



SLOTTED INSERT BITS



SCREW SIZE	BLADE THICKNESS (approx.)	BLADE WIDTH (approx.)	OVERALL LENGTH	PART NO.	PART NO.		
				AIRCRAFT (Machine Screws)	INDUSTRIAL (Self Tapping Screws)		
2F-3R	.026"	.138"	1"	H3199A	H3199X		
3F-4R	.030"	.154"	1"	H3201A	H3201X		
5F-6R	.036"	.219"	1"	H3205A	H3205X		
4F-5R	.034"	.170"	1"	H3211A	H3211X		
6F-8R	.040"	.219"	1"	H3212A	H3212X		
8F-10R	.042"	.250"	1"	H3213A	H3213X		
10F-12R	.046"	.281"	1"	H3214A	H3214X		
12F-14R	.050"	.297"	1"	H3215A	H3215X		
2F-3R	.026"	.138"	1 1/2"	H3219A	H3219X		
3F-4R	.030"	.154"	1 1/2"	H3220A	H3220X		
4F-5R	.034"	.188"	1 1/2"	H3221A	H3221X		
6F-8R	.040"	.218"	1 1/2"	H3222A	H3222X		
8F-10R	.042"	.250"	1 1/2"	H3223A	H3223X		
10F-12R	.046"	.281"	1 1/2"	H3224A	H3224X		
12F-14R	.050"	.297"	1 1/2"	H3225A	H3225X		
14F-16R	.055"	.344"	1 1/2"	H3226A	H3226X		
4F-5R	.034"	.188"	1 1/2"	H3231A	H3231X		
6F-8R	.040"	.218"	1 1/2"	H3232A	H3232X		
8F-10R	.042"	.250"	1 1/2"	H3233A	H3233X		
10F-12R	.046"	.281"	1 1/2"	H3234A	H3234X		
12F-14R	.050"	.297"	1 1/2"	H3235A	H3235X		
14F-16R	.055"	.344"	1 1/2"	H3236A	H3236X		

SLOTTED POWER BITS



SCREW SIZE	BLADE THICKNESS (approx.)	BLADE WIDTH (approx.)	OVERALL LENGTH	PART NO.	PART NO.	
				AIRCRAFT (Machine Screws)	INDUSTRIAL (Self Tapping Screws)	
4F-5R	.034"	.188"	1 15/16"	—	E3541X	
5F-6R	.036"	.250"	1 15/16"	—	E3542X	
8F-10R	.042"	.275"	1 15/16"	E3104A	E3104X	
10F-12R	.046"	.312"	1 15/16"	E3105A	E3105X	
12F-14R	.050"	.360"	1 15/16"	E3106A	E3106X	
8F-10R	.042"	.275"	2 3/4"	E3104A275	E3104X275	
10F-12R	.046"	.312"	2 3/4"	E3105A275	E3105X275	
12F-14R	.050"	.360"	2 3/4"	E3106A275	E3106X275	
8F-10R	.042"	.275"	3"	E3104A3	E3104X3	
10F-12R	.046"	.312"	3"	E3105A3	E3105X3	
12F-14R	.050"	.360"	3"	E3106A3	E3106X3	
1F-2R	.022"	.122"	1 15/16"	E3098A	E3098X	
3F-4R	.030"	.154"	1 15/16"	E3100A	E3100X	
1F-2R	.022"	.122"	3"	E3098A3	E3098X3	
3F-4R	.030"	.154"	3"	E3100A3	E3100X3	
4F-5R	.034"	.188"	1 15/16"	E3101A	E3101X	
5F-6R	.036"	.250"	1 15/16"	E3102A	E3102X	
6F-7R	.038"	.250"	1 15/16"	E3103A	E3103X	
4F-5R	.034"	.188"	2 3/4"	E3101A275	E3101X275	
5F-6R	.036"	.250"	2 3/4"	E3102A275	E3102X275	
6F-7R	.038"	.250"	2 3/4"	E3103A275	E3103X275	
4F-5R	.034"	.188"	3"	E3101A3	E3101X3	
5F-6R	.036"	.250"	3"	E3102A3	E3102X3	
6F-7R	.038"	.250"	3"	E3103A3	E3103X3	
6F-7R	.038"	.250"	4"	—	E3103X4	
6F-7R	.038"	.250"	2 1/4"	E3203A	E3203X	
7F-8R	.040"	.275"	2 1/4"	E3204A	E3204X	
8F-10R	.042"	.312"	2 1/4"	E3205A	E3205X	
10F-12R	.046"	.360"	2 1/4"	E3206A	E3206X	
12F-14R	.050"	.395"	2 1/4"	E3207A	E3207X	
14F-16R	.055"	.475"	2 1/4"	E3208A	E3208X	
16F-18R	.060"	.503"	2 1/4"	E3209A	E3209X	
18F-20R	.062"	.545"	2 1/4"	E3200A	E3200X	



ACR®-POZIDRIV® INSERT BITS ACR-B 4X4™

	POINT SIZE	OVERALL LENGTH	PART NO. INDUSTRIAL (Self Tapping Screws)
1/4" hex shank 	1	1"	PZ1221XACR-B
	2	1"	PZ1222XACR-B
	3	1"	PZ1223XACR-B







ACR®-POZIDRIV® POWER BITS ACR-B 4X4™

	BODY DIAMETER	POINT SIZE	OVERALL LENGTH	PART NO. INDUSTRIAL (Self Tapping Screws)
1/4" hex shank 	1/4"	2	1 ¹⁵ / ₁₆ "	PZ1102XACR-B

ACR® Pozidriv Power bits available in 2³/₄", 3¹/₂" and 6" lengths on request.





POZIDRIV® INSERT BITS

	POINT SIZE	OVERALL LENGTH	PART NO. AIRCRAFT (Machine Screws)	PART NO. INDUSTRIAL (Self Tapping Screws)
1/4" hex shank  	1	1"	PZ1221A	PZ1221X
	2	1"	PZ1222A	PZ1222X
	2	1 ¹ / ₂ "	PZ1222A15	PZ1222X15
	2	2"	PZ1222A2	PZ1222X2
	2	2 ¹ / ₂ "	PZ1222A25	PZ1222X25
	3	1"	PZ1223A	PZ1223X
Reduced Nose Diameter 	2	1"	PZ1227A	PZ1227X
	1	1"	PZ1228A	PZ1228X
5/16" hex shank 	1	1 ¹ / ₄ "	PZ1231A	PZ1231X
	2	1 ¹ / ₄ "	PZ1232A	PZ1232X
	3	1 ¹ / ₄ "	PZ1233A	PZ1233X
	4	1 ¹ / ₄ "	PZ1234A	PZ1234X





POZIDRIV® POWER BITS

	BODY DIAMETER	POINT SIZE	OVERALL LENGTH	PART NO. AIRCRAFT (Machine Screws)	PART NO. INDUSTRIAL (Self Tapping Screws)
1/4" hex shank 	3/16"	1	1 ¹⁵ / ₁₆ "	PZ1101A	PZ1101X
	1/4"	2	1 ¹⁵ / ₁₆ "	PZ1102A	PZ1102X
	1/4"	3	1 ¹⁵ / ₁₆ "	PZ1103A	PZ1103X
	3/16"	1	2 ³ / ₄ "	PZ1101A275	PZ1101X275
	1/4"	2	2 ³ / ₄ "	PZ1102A275	PZ1102X275
	1/4"	3	2 ³ / ₄ "	PZ1103A275	PZ1103X275
	3/16"	1	3 ¹ / ₂ "	PZ1101A35	PZ1101X35
	1/4"	2	3 ¹ / ₂ "	PZ1102A35	PZ1102X35
	1/4"	3	3 ¹ / ₂ "	PZ1103A35	PZ1103X35
	1/4"	2	6"	PZ1102A6	PZ1102X6
5/16" hex shank 	3/16"	1	3"	PZ1201A	PZ1201X
	1/4"	2	3"	PZ1202A	PZ1202X
	5/16"	3	3"	PZ1203A	PZ1203X

Pozidriv® is a registered trademark of the Phillips Screw Company



FRENCH RECESS INSERT BITS (B.N.A.E.)





POINT SIZE	OVERALL LENGTH	PART NO. AIRCRAFT (Machine Screws)	PART NO. INDUSTRIAL (Self Tapping Screws)	
4	1"	H7224AA	H7224XX	1/4" hex shank 
5	1"	H7225AA	H7225XX	
6	1"	H7226AA	H7226XX	
8	1"	H7228AA	H7228XX	
6	1 1/4"	H7326AA	H7326XX	5/16" hex shank 
8	1 1/4"	H7328AA	H7328XX	

SOCKET (ALLEN) HEAD INSERT BITS



HEX SIZE	OVERALL LENGTH	PART NO. AIRCRAFT (Machine Screws)	PART NO. INDUSTRIAL (Self Tapping Screws)	
5/32"	1"	—	H5207X	1/4" hex shank 
3/16"	1"	—	H5208X	
7/32"	1"	—	H5209X	
1/4"	1"	—	H5210X	
5/16"	1"	—	H5211X	
3/8"	1"	—	H5212X	
1/16"	1"	H5221A	H5221X	
5/64"	1"	H5222A	H5222X	
3/32"	1"	H5223A	H5223X	
7/64"	1"	H5224A	H5224X	
1/8"	1"	H5225A	H5225X	
9/64"	1"	H5226A	H5226X	
5/32"	1 5/16"	H5227A	H5227X	
3/16"	1 5/16"	H5228A	H5228X	
7/32"	1 5/16"	H5229A	H5229X	
1/4"	1 5/16"	H5220A	H5220X	
5/32"	1 5/16"	H5234A	H5234X	5/16" hex shank 
3/16"	1 5/16"	H5235A	H5235X	
7/32"	1 5/16"	H5236A	H5236X	
1/4"	1 5/16"	H5237A	H5237X	
5/16"	1 5/16"	H5238A	H5238X	
3/8"	1 5/16"	H5239A	H5239X	

HEX SIZE MILLIMETER	OVERALL LENGTH MM	OVERALL LENGTH IN.	ZEPHYR PART NO.	
1,5	25,4	1"	H52215XM	1/4" hex shank metric 
2	25,4	1"	H5222XM	
2,5	25,4	1"	H52225XM	
3	25,4	1"	H5223XM	
4	25,4	1"	H5204XM	
5	25,4	1"	H5205XM	
6	25,4	1"	H5206XM	
7	25,4	1"	H5207XM	
8	25,4	1"	H5208XM	
4	33,3	1 5/16"	H5224XM	
5	33,3	1 5/16"	H5225XM	
6	33,3	1 5/16"	H5226XM	
7	33,3	1 5/16"	H5227XM	
8	31,7	1 1/4"	H5228XM	
5	33,3	1 5/16"	H5235XM	5/16" hex shank metric 
6	33,3	1 5/16"	H5236XM	
8	33,3	1 5/16"	H5238XM	
10	33,3	1 5/16"	H5230XM	





SOCKET (ALLEN) HEAD TAMPER RESISTANT INSERT BITS

	HEX SIZE	OVERALL LENGTH	ZEPHYR PART NO.
1/4" hex shank 	5/64"	1"	H5222TX
	3/32"	1"	H5223TX
	7/64"	1"	H5224TX
	1/8"	1"	H5225TX
	9/64"	1"	H5226TX
	7/32"	1"	H5209TX
	3/16"	1"	H5208TX



SOCKET (ALLEN) HEAD POWER BITS

	HEX SIZE	OVERALL LENGTH	ZEPHYR PART NO.
1/4" hex shank 	1/16"	1 15/16"	E5101X
	5/64"	1 15/16"	E5102X
	3/32"	1 15/16"	E5103X
	7/64"	1 15/16"	E5104X
	1/8"	1 15/16"	E5105X
	9/64"	1 15/16"	E5106X
	5/32"	1 15/16"	E5107X
	3/16"	1 15/16"	E5108X
	7/32"	1 15/16"	E5109X
	1/4"	1 15/16"	E5110X
	5/16"	1 15/16"	E5111X

	HEX SIZE MILLIMETER	OVERALL LENGTH MM	OVERALL LENGTH IN.	ZEPHYR PART NO.
1/4" hex shank metric 	2	49,2	1 15/16"	E5102XM
	2,5	49,2	1 15/16"	E51025XM
	3	49,2	1 15/16"	E5103XM
	4	49,2	1 15/16"	E5104XM
	5	49,2	1 15/16"	E5105XM
	6	49,2	1 15/16"	E5106XM
	8	49,2	1 15/16"	E5108XM
7/16" hex shank metric 	5	88,9	3 1/2"	E5095XM35
	6	88,9	3 1/2"	E5096XM35
	8	88,9	3 1/2"	E5098XM35
	10	88,9	3 1/2"	E5090XM35



SQUARE RECESS INSERT BITS

	POINT SIZE	SCREW SIZE	OVERALL LENGTH	ZEPHYR PART NO.
1/4" hex shank 	0	3 & 4	1"	H8100XX
	1	5, 6, 7	1"	H8101XX
	2	8, 9, 10	1"	H8102XX
	3	12, 14, 1/4	1"	H8103XX

SQUARE RECESS POWER BITS



POINT SIZE	SCREW SIZE	OVERALL LENGTH	BODY DIA	ZEPHYR PART NO.
0	3 & 4	1 ¹⁵ / ₁₆ "	—	E8540XX
1	5, 6, 7	1 ¹⁵ / ₁₆ "	—	E8541XX
2	8, 9, 10	1 ¹⁵ / ₁₆ "	—	E8542XX
3	12, 14, ¼	1 ¹⁵ / ₁₆ "	—	E8543XX
0	3 & 4	2 ³ / ₄ "	—	E8540XX275
1	5, 6, 7	2 ³ / ₄ "	—	E8541XX275
2	8, 9, 10	2 ³ / ₄ "	—	E8542XX275
3	12, 14, ¼	2 ³ / ₄ "	—	E8543XX275
0	3 & 4	1 ¹⁵ / ₁₆ "	3/16"	E8100XX
1	5, 6, 7	1 ¹⁵ / ₁₆ "	3/16"	E8101XX
2	8, 9, 10	1 ¹⁵ / ₁₆ "	¼"	E8102XX
3	12, 14, ¼	1 ¹⁵ / ₁₆ "	¼"	E8103XX
0	3 & 4	2 ³ / ₄ "	3/16"	E8100XX275
1	5, 6, 7	2 ³ / ₄ "	3/16"	E8101XX275
2	8, 9, 10	2 ³ / ₄ "	¼"	E8102XX275
3	12, 14, ¼	2 ³ / ₄ "	¼"	E8103XX275
0	3 & 4	3½"	3/16"	E8100XX35
1	5, 6, 7	3½"	3/16"	E8101XX35
2	8, 9, 10	3½"	¼"	E8102XX35
3	12, 14, ¼	3½"	¼"	E8103XX35

Note: Lengths up to 6" available on request.

1/4" hex shank



Full Body Hex

Reduced Shank Diameter



TORX® INSERT BITS



POINT SIZE	PT. SIZE (REF.)	OVERALL LENGTH	ZEPHYR PART NO.
T5	.055"	1"	Z0T5X
T6	.065"	1"	Z0T6X
T7	.077"	1"	Z0T7X
T8	.090"	1"	Z0T8X
T9	.097"	1"	Z0T9X
T10	.107"	1"	Z0T10X
T15	.128"	1"	Z0T15X
T20	.151"	1"	Z0T20X
T25	.173"	1"	Z0T25X
T27	.195"	1"	Z0T27X
T30	.216"	1"	Z0T30X
T40	.260"	1"	Z0T40X
T30	.216"	1¼"	Z5T30X
T40	.260"	1¼"	Z5T40X
T45	.306"	1¼"	Z5T45X
T50	.346"	1¼"	Z5T50X
T55	.440"	1¼"	Z5T55X

Torx® is a registered trademark of the Camcar Division of Textron.

Note: Other Torx® sizes available on request.

1/4" hex shank



5/16" hex shank



TORX® INSERT BITS TAMPER RESISTANT



POINT SIZE	PT. SIZE (REF.)	OVERALL LENGTH	ZEPHYR PART NO.
T7	.077"	1"	Z0T7TX
T8	.090"	1"	Z0T8TX
T9	.097"	1"	Z0T9TX
T10	.107"	1"	Z0T10TX
T15	.128"	1"	Z0T15TX
T20	.151"	1"	Z0T20TX
T25	.173"	1"	Z0T25TX
T27	.195"	1"	Z0T27TX
T30	.216"	1"	Z0T30TX
T40	.260"	1"	Z0T40TX

1/4" hex shank







TORX® INSERT BITS TAMPER RESISTANT (Continued)

	POINT SIZE	PT. SIZE (REF)	OVERALL LENGTH	ZEPHYR PART NO.
5/16" hex shank 	T45	.306"	1 1/4"	Z5T45TX
	T50	.346"	1 1/4"	Z5T50TX
	T55	.440"	1 1/4"	Z5T55TX



TORX® POWER BITS

	BODY DIAMETER (REF)	POINT SIZE	POINT SIZE (REF)	OVERALL LENGTH	ZEPHYR PART NO.
1/4" hex shank  	1/8"	T6	.065"	1 15/16"	ZPT6X
	1/8"	T7	.077"	1 15/16"	ZPT7X
	1/8"	T8	.090"	1 15/16"	ZPT8X
	1/8"	T9	.097"	1 15/16"	ZPT9X
	5/32"	T10	.107"	1 15/16"	ZPT10X
	5/32"	T15	.128"	1 15/16"	ZPT15X
	3/16"	T20	.151"	1 15/16"	ZPT20X
	3/16"	T25	.173"	1 15/16"	ZPT25X
	1/4"	T27	.195"	1 15/16"	ZPT27X
	1/4"	T30	.216"	1 15/16"	ZPT30X
	5/16"	T40	.260"	1 15/16"	ZPT40X
	1/8"	T7	.077"	2 3/4"	ZPT7X275
	1/8"	T8	.090"	2 3/4"	ZPT8X275
	1/8"	T9	.097"	2 3/4"	ZPT9X275
	5/32"	T10	.107"	2 3/4"	ZPT10X275
	5/32"	T15	.128"	2 3/4"	ZPT15X275
	3/16"	T20	.151"	2 3/4"	ZPT20X275
	3/16"	T25	.173"	2 3/4"	ZPT25X275
	1/4"	T27	.195"	2 3/4"	ZPT27X275
	1/4"	T30	.216"	2 3/4"	ZPT30X275
	5/16"	T40	.260"	2 3/4"	ZPT40X275
	1/8"	T7	.077"	3 1/2"	ZPT7X35
	1/8"	T8	.090"	3 1/2"	ZPT8X35
	1/8"	T9	.097"	3 1/2"	ZPT9X35
	5/32"	T10	.107"	3 1/2"	ZPT10X35
	5/32"	T15	.128"	3 1/2"	ZPT15X35
	3/16"	T20	.151"	3 1/2"	ZPT20X35
	3/16"	T25	.173"	3 1/2"	ZPT25X35
	1/4"	T27	.195"	3 1/2"	ZPT27X35
	1/4"	T30	.216"	3 1/2"	ZPT30X35
	5/16"	T40	.260"	3 1/2"	ZPT40X35
	1/8"	T7	.077"	6"	ZPT7X6
	1/8"	T8	.090"	6"	ZPT8X6
	1/8"	T9	.097"	6"	ZPT9X6
	5/32"	T10	.107"	6"	ZPT10X6
	5/32"	T15	.128"	6"	ZPT15X6
	3/16"	T20	.151"	6"	ZPT20X6
	3/16"	T25	.173"	6"	ZPT25X6
	1/4"	T27	.195"	6"	ZPT27X6
	1/4"	T30	.216"	6"	ZPT30X6
1/4"	T40	.260"	6"	ZPT40X6	





TORX® POWER BITS TAMPER RESISTANT

	BODY DIAMETER (REF)	POINT SIZE	POINT SIZE (REF)	OVERALL LENGTH	ZEPHYR PART NO.
1/4" hex shank 	5/32"	T10	.107"	1 15/16"	ZPT10TX
	5/32"	T15	.128"	1 15/16"	ZPT15TX
	3/16"	T20	.151"	1 15/16"	ZPT20TX
	3/16"	T25	.173"	1 15/16"	ZPT25TX



TORX PLUS® INSERT BITS



POINT SIZE	PT. SIZE (REF.)	OVERALL LENGTH	ZEPHYR PART NO.	
10IP	.107"	1"	Z0T10IP	1/4" hex shank 
15IP	.128"	1"	Z0T15IP	
20IP	.151"	1"	Z0T20IP	
25IP	.173"	1"	Z0T25IP	
30IP	.195"	1"	Z0T30IP	
40IP	.260"	1 1/4"	Z5T40IP	5/16" hex shank 
45IP	.306"	1 1/4"	Z5T45IP	
50IP	.346"	1 1/4"	Z5T50IP	
55IP	.440"	1 1/2"	Z7T55IP	7/16" hex shank
60IP	.520"	1 1/2"	Z8T60IP	1/2" hex shank



SPANNER TAMPER RESISTANT



POINT SIZE	PT. SIZE (REF.)	OVERALL LENGTH	ZEPHYR PART NO.	
#4	.130"	1"	J9221	1/4" hex shank 
#6	.174"	1"	J9222	
#8	.211"	1"	J9223	
#10	.249"	1"	J9224	
#1/4	.323"			
#4	.130"	1 1/2"	J9231A	5/16" hex shank 
#6	.174"	1 1/2"	J9232A	
#8	.211"	1 1/2"	J9233A	

TORQ-SET®-ACR® INSERT BITS



OVERALL LENGTH	SCREW SIZE	ZEPHYR PART NO.	
1"	6	TS212-6R	1/4" hex shank 
1"	8	TS212-8R	
1"	10	TS212-10R	
1"	1/4	TS212-1/4R	
1 1/4"	8	TS212-8AR	5/16" hex shank 
1 1/4"	10	TS212-10AR	
1 1/4"	1/4	TS212-1/4AR	
1 1/4"	5/16	TS212-5/16AR	

TORQ-SET®-ACR® POWER BITS



BODY DIA.	OVERALL LENGTH	SCREW SIZE	ZEPHYR PART NO.	
—	1 1/4"	6	TS170-6R	1/4" hex shank 
—	1 1/4"	8	TS170-8R	
—	1 1/4"	10	TS170-10R	
3/16"	1 5/16"	6	TS273-6R	
1/4"	1 5/16"	8	TS273-8R	
1/4"	1 5/16"	10	TS273-10R	
3/16"	3 1/2"	6	TS265-6-35R	
1/4"	3 1/2"	8	TS265-8-35R	
1/4"	3 1/2"	10	TS265-10-35R	
—	1 1/4"	1/4	TS170-1/4AR	
—	1 1/4"	5/16	TS170-5/16AR	



TORQ-SET®-ACR® POWER BITS (Continued)

	BODY DIA.	OVERALL LENGTH	SCREW SIZE	ZEPHYR PART NO.
7/16" hex shank 	—	1 1/4"	1/4	TS170-1/4R
	—	1 1/4"	5/16	TS170-5/16R
	1 1/32"	3 1/2"	1/4	TS265-1/4-35R
	3/8"	3 1/2"	5/16	TS265-5/16-35R

TORQ-SET®-ACR® is registered trademark of Phillips Screw Co. TORQ-SET®-ACR® driver bits are produced in accordance with MS33781 and the most current Phillips Screw Co. specifications. Note: Other TORQ-SET®-ACR® sizes available on request.



Why use TORQ-SET®-ACR® bits...

Removal of TORQ-SET® fasteners can require up to three times the torque of installation due to corrosion and shear loading. Bit "purchase" (contact surface area) is also reduced by paint and corrosion in the bottom of the fastener recess. Cam-out often occurs. Cam-out fatigues the operator and damages the work, usually requiring expensive drill out of the fastener.

To reduce cam-outs, Zephyr TORQ-SET®-ACR® bits provide better recess fit, bit "purchase," and delivered torque.



TORQ-SET® INSERT BITS

	OVERALL LENGTH	SCREW SIZE	ZEPHYR PART NO.
1/4" hex shank 	1"	0	TS212-0
	1"	1	TS212-1
	1"	2	TS212-2
	1"	3	TS212-3
	1"	4	TS212-4
	1"	5	TS212-5
	1"	6	TS212-6
	1"	8	TS212-8
	1"	10	TS212-10
	1"	1/4	TS212-1/4
1/4" hex shank bullnose 	1"	1/4	TS212-1/4B
	1"	5/16	TS212-5/16B
5/16" hex shank 	1 1/4"	8	TS212-8A
	1 1/4"	10	TS212-10A
	1 1/4"	1/4	TS212-1/4A
	1 1/4"	5/16	TS212-5/16A
	1 1/4"	3/8	TS212-3/8A



TORQ-SET® POWER BITS



	BODY DIA.	OVERALL LENGTH	SCREW SIZE	ZEPHYR PART NO.
1/4" hex shank 	—	1 1/4"	0	TS170-0
	—	1 1/4"	1	TS170-1
	—	1 1/4"	2	TS170-2
	—	1 1/4"	3	TS170-3
	—	1 1/4"	4	TS170-4
	—	1 1/4"	5	TS170-5
	—	1 1/4"	6	TS170-6
	—	1 1/4"	8	TS170-8
	—	1 1/4"	10	TS170-10

Continued on page 13

Torq-Set® is a registered trademark of Phillips Screw Co. Torq-Set® driver bits are produced in accordance with MS 33781 and the most current Phillips Screw Co. specifications.



TORQ-SET® POWER BITS (Continued)



BODY DIA	OVERALL LENGTH	SCREW SIZE	ZEPHYR PART NO.		
—	1¼"	¼"	TS170-¼B	1/4" hex shank	
—	1¼"	5/16"	TS170-5/16B		
—	1¼"	3/8"	TS170-3/8B		
1/8"	1½"	0	TS273-0	Bullnose 	
1/8"	1½"	1	TS273-1		
1/8"	1½"	2	TS273-2		
5/32"	1½"	3	TS273-3		
5/32"	1½"	4	TS273-4		
3/16"	1½"	5	TS273-5		
3/16"	1½"	6	TS273-6		
1/4"	1½"	8	TS273-8		
1/4"	1½"	10	TS273-10		
1/8"	3½"	0	TS265-0-35		
1/8"	3½"	1	TS265-1-35		
1/8"	3½"	2	TS265-2-35		
5/32"	3½"	3	TS265-3-35		
5/32"	3½"	4	TS265-4-35		
3/16"	3½"	5	TS265-5-35		
3/16"	3½"	6	TS265-6-35		
1/4"	3½"	8	TS265-8-35		
1/4"	3½"	10	TS265-10-35		
1/8"	6"	0	TS265-0-6		
1/8"	6"	1	TS265-1-6		
1/8"	6"	2	TS265-2-6		
5/32"	6"	3	TS265-3-6		
5/32"	6"	4	TS265-4-6		
3/16"	6"	5	TS265-5-6		
3/16"	6"	6	TS265-6-6		
1/4"	6"	8	TS265-8-6		
1/4"	6"	10	TS265-10-6		
—	1¼"	8	TS170-8A		5/16" hex shank
—	1¼"	10	TS170-10A		
—	1¼"	¼"	TS170-¼A	Bullnose 	
—	1¼"	5/16"	TS170-5/16A		
—	1¼"	3/8"	TS170-3/8A		
—	1¼"	7/16"	TS170-7/16A		
—	1¼"	½"	TS170-½A		
—	1¼"	¼"	TS170-¼	7/16" hex shank 	
—	1¼"	5/16"	TS170-5/16		
—	1¼"	3/8"	TS170-3/8		
—	1¼"	7/16"	TS170-7/16		
11/32"	1½"	¼"	TS273-¼		
3/8"	1½"	5/16"	TS273-5/16		
7/16"	1½"	3/8"	TS273-3/8		
7/16"	1½"	7/16"	TS273-7/16		
11/32"	3½"	¼"	TS265-¼-35		
3/8"	3½"	5/16"	TS265-5/16-35		
7/16"	3½"	3/8"	TS265-3/8-35		
7/16"	3½"	7/16"	TS265-7/16-35		
11/32"	6"	¼"	TS265-¼-6		
3/8"	6"	5/16"	TS265-5/16-6		
7/16"	6"	3/8"	TS265-3/8-6		
7/16"	6"	7/16"	TS265-7/16-6		
—	1¼"	½"	TS170-½		5/8" hex shank 
—	1¼"	9/16"	TS170-9/16		
—	1¼"	5/8"	TS170-5/8		





TRI-WING®-ACR® INSERT BITS

	OVERALL LENGTH	RECESS NO.	SCREW SIZE		ZEPHYR PART NO.
			TENSION HEAD	SHEAR HEAD	
1/4" hex shank 	1"	3	6-32	8-32	TW-3DR
	1"	4	8-32	10-32	TW-4DR
	1"	5	10-32	1/4-28	TW-5DR
1/4" hex shank bullnose 	1 1/4"	6	1/4-28	5/16-24	TW-6B4DR
5/16" hex shank 	1 1/4"	4	8-32	10-32	TW-4ADR
	1 1/4"	5	10-32	1/4-28	TW-5ADR
	1 1/4"	6	1/4-28	5/16-24	TW-6ADR



TRI-WING®-ACR® POWER BITS

	OVERALL LENGTH	RECESS NO.	SCREW SIZE		ZEPHYR PART NO.
			TENSION HEAD	SHEAR HEAD	
1/4" hex shank 	1 1/4"	3	6-32	8-32	TW-3R
	1 1/4"	4	8-32	10-32	TW-4R
	1 1/4"	5	10-32	1/4-28	TW-5R
1/4" hex bullnose 	1 1/4"	6	1/4-28	5/16-24	TW-6B4R
7/16" hex shank 	1 1/4"	6	1/4-28	5/16-24	TW-6R
	1 1/4"	7	5/16-24	3/8-24	TW-7R

TRI-WING®-ACR® is a registered trademark of Phillips Screw Company
 TRI-WING® Driver Bit dimensions are produced to NAS-4005 and the most current Phillips Screw Co. specifications.
 Note: Other TRI-WING®-ACR® sizes available on request.



'Match the Numbers'
Driver to Recess



Why use TRI-WING®-ACR® bits...

Removal of TRI-WING® fasteners can require up to three times the torque of installation due to corrosion and shear loading. Bit "purchase" (contact surface area) is also reduced by paint and corrosion in the bottom of the fastener recess. Cam-out often occurs. Cam-out fatigues the operator and damages the work, usually requiring expensive drill out of the fastener.

To reduce cam-outs, Zephyr TRI-WING®-ACR® bits provide better recess fit, bit "purchase," and delivered torque.

**WHY WE'RE A BIT
BETTER THAN
THE COMPETITION.**



ZEPHYR[®]
SCREWDRIVING TOOLS

HERE'S WHY ZEPHYR GIVES BITS THAT BITE...

Zephyr offers the broadest selection and highest quality conventional and ACR Anti-Cam-out Recess bits on the market. The combination of ACR and Zephyr Z-Forge™ provides the best available quality through a unique single operation, which forms the ribs on the bit as it is forged. The Z-Forge™ process provides the optimal change in grain flow so that Zephyr bits provide higher torque with increased hardness.

Zephyr ACR bits are currently available in Phillips, Pozidriv®, TRI-WING® and TORQ-SET®. Our research indicates a substantial improvement in fastening efficiency and significant reduction in "cam-out" using an ACR® driver with standard fasteners. Zephyr ACR bits enhance delivered torque to ACR® and standard recesses. Even in off-angle driving the ACR bits bite delivers in high-torque grip.

Z-FORGE™ MEANS QUALITY

A forged bit is a better bit. When a Zephyr bit is forged it is shaped precisely in a machine tool die. When that die has delivered a specific number of bits it is replaced. In this way consistent, precision sizing is maintained on all Zephyr bits.

Milling steel to achieve the desired shape cannot achieve consistent quality. Variation in fit results in increased cam-out and shorter tool life.

ACR® is a registered trademark of the Phillips Screw Company.
ZEPHYR™ is a registered trademark of Zephyr Manufacturing Company, Inc.



ZEPHYR PRECISION FIT...

A master gauge is used to check the fit of each Zephyr bit. Although the cost of a bit is small, it is the part of the tool which controls the quality of the fastening job. At Zephyr we make sure that the fit is right—that is what you are paying for.



TESTING FOR EXACT HARDNESS...

The grade of the bit is important because hardness is a major factor in tool life and workability. The Zephyr quality control department consistently checks each lot for exact Rockwell hardness to adhere to our own high specifications. Zephyr is the only major bit manufacturer that maintains lot samples from all production runs. This control feature ensures you receive the best and most consistent quality available.



SMALL BATCH HEAT TREATING...

Carefully controlled heat treating by Zephyr assures consistency. Specially designed laboratory and physical tests are performed. Our proprietary heat treating system achieves a consistent level of hardness combined with toughness.

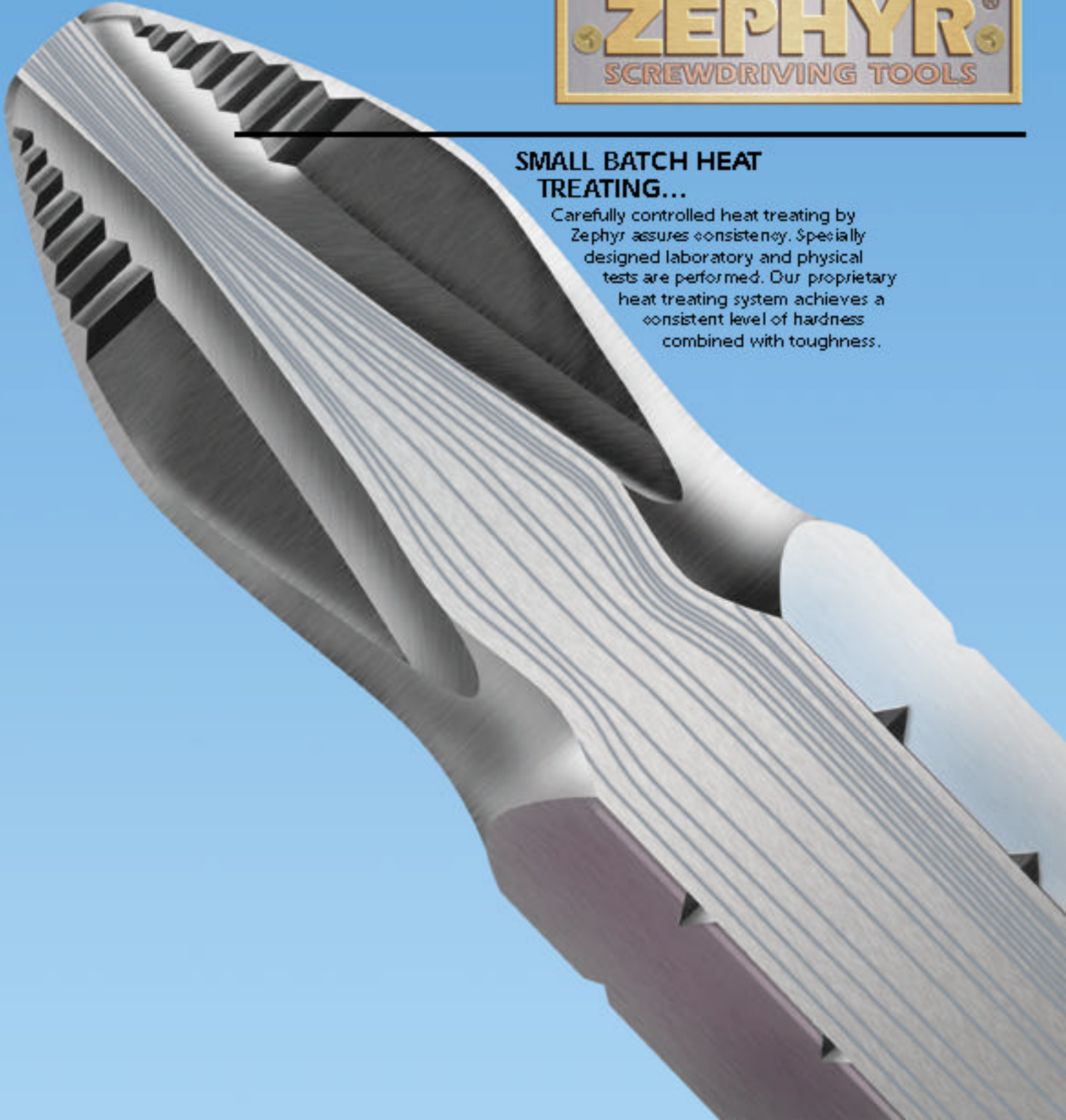

ZEPHYR PUTS A BITE INTO INDUSTRY...

**AEROSPACE
APPLIANCES
ASSEMBLY
AUTOMOTIVE
CONSTRUCTION
DRYWALL
ELECTRONICS
FURNITURE
MANUFACTURING
UTILITIES**

CUSTOMER INSPECTION IS INVITED...

As a major supplier of aerospace tools Zephyr has been producing to the high quality standards of military contractors and commercial airframe manufacturers for 60 years. We invite your inspection of our facilities. Zephyr engineers will be pleased to develop exact specifications for the bits your particular manufacturing or service jobs require.

OUR CUSTOMERS ARE OUR BEST SALESMEN...

Let Zephyr's customers tell you the difference. The testimonials below are just a few of the many Zephyr success stories from industry. We will be pleased to provide references in your industry. Zephyr sales and engineering personnel will also be pleased to arrange a competitive test of Zephyr bits against any other bit you are currently using. Zephyr may cost slightly more than the "low bid" bit but over the life of Zephyr bit the cost is less.

THE ZEPHYR CHALLENGE...

Zephyr challenges any customer or distributor to test the Zephyr bit of your choice under controlled conditions. Ask our engineering department to help you design a test for your type of operation. The Zephyr ACR® bits out-perform and outlast any bits on the market. Find out for yourself. Zephyr will try to meet any challenge you can create.

A FEW EXAMPLES OF ZEPHYR ACR® QUALITY AND PERFORMANCE...

200 Miles above the earth on a NASA Discover mission a repair had to be made to the 7.5 ton LEASAT communications satellite—the tool, an ACR® Multi Ribbed TORQ-SET® bit.

To view objects 4 billion light years away the Space Telescope floats above the earth. The Space Telescope is designed to allow modules to be replaced on future orbital flights—the tool, a TORQ-SET® bit.

Sophisticated audio equipment looks like amateur stuff if the case is scarred by cam-out when the screws are set. One manufacturer solved this problem with the ACR® system and achieved lower costs while eliminating quality control problems caused by cam-out.

A cam-out during assembly of a printed circuit board means trouble. When a major board manufacturer experienced these problems—the solution—the ACR® Multi Ribbed system. Torque delivery improved over 200% while cam-out was eliminated.

Cam-out on a plastic air spoiler installed at the end of the production line in an auto assembly plant caused expensive rework. The ACR® system came to the rescue eliminating cam-out and speeding production while lowering costs.

These are only a few of the hundreds of testimonials to Zephyr bits. Let your Zephyr distributor or representative tell you more about Zephyr quality and service.





Zephyr Circle Z means quality and reliability...

ACR®, TORQ-SET®, TORQ-SET®-ACR® are registered trademarks of Phillips Screw Company.

201 HINDRY AVENUE, INGLEWOOD, CA 90301-1519
(310) 410-4907 (800) 624-3944 (OUTSIDE CA.) FAX: (310) 410-2913
Email: zephyr@zephyrtool.com
<http://www.zephyrtool.com>





TRI-WING® INSERT BITS



OVERALL LENGTH	RECESS NO.	SCREW SIZE		ZEPHYR PART NO.	
		TENSION HEAD	SHEAR HEAD		
1"	0	0-80	—	TW-0D	1/4" hex shank 
1"	1	2-56	4-40	TW-1D	
1"	2	4-40	6-32	TW-2D	
1"	3	6-32	8-32	TW-3D	
1"	4	8-32	10-32	TW-4D	
1"	5	10-32	1/4-28	TW-5D	
1 1/4"	4	8-32	10-32	TW-4AD	5/16" hex shank 
1 1/4"	5	10-32	1/4-28	TW-5AD	
1 1/4"	6	1/4-28	5/16-24	TW-6AD	
1 1/4"	6	1/4-28	5/16-24	TW-6B4D	1/4" hex shank bullnose 
1 1/4"	7	5/16-24	3/8-24	TW-7B4D	
1 1/4"	8	3/8-24	7/16-20	TW-8B4D	
1 1/4"	6	1/4-28	5/16-24	TW-6B5D	5/16" hex shank bullnose 
1 1/4"	7	5/16-24	3/8-24	TW-7B5D	
1 1/4"	8	3/8-24	7/16-20	TW-8B5D	

TRI-WING® POWER BITS







OVERALL LENGTH	RECESS NO.	SCREW SIZE		ZEPHYR PART NO.	
		TENSION HEAD	SHEAR HEAD		
1 1/4"	0	0-80	—	TW-0	1/4" hex shank 
1 1/4"	1	2-56	4-40	TW-1	
1 1/4"	2	4-40	6-32	TW-2	
1 1/4"	3	6-32	8-32	TW-3	
1 1/4"	4	8-32	10-32	TW-4	
1 1/4"	5	10-32	1/4-28	TW-5	5/16" hex shank 
1 1/4"	4	8-32	10-32	TW-4A	
1 1/4"	5	10-32	1/4-28	TW-5A	7/16" hex shank 
1 1/4"	6	1/4-28	5/16-24	TW-6	
1 1/4"	7	5/16-24	3/8-24	TW-7	
1 1/4"	8	3/8-24	7/16-20	TW-8	5/8" hex shank 
1 1/4"	9	7/16-20	1/2-20	TW-9	
1 1/4"	10	1/2-20	9/16-18	TW-10	
1 1/4"	11	9/16-18	5/8-18	TW-11	
1 1/4"	6	1/4-28	5/16-24	TW-6B4	1/4" hex shank bullnose 
1 1/4"	7	5/16-24	3/8-24	TW-7B4	
1 1/4"	8	3/8-24	7/16-20	TW-8B4	

Continued on next page



TRI-WING® POWER BITS (Continued)

	OVERALL LENGTH	RECESS NO.	SCREW SIZE		ZEPHYR PART NO.
			TENSION HEAD	SHEAR HEAD	
5/16" hex shank bullnose 	1 1/4"	6	1/4-28	5/16-24	TW-6B5
	1 1/4"	7	5/16-24	3/8-24	TW-7B5
	1 1/4"	8	3/8-24	7/16-20	TW-8B5
7/16" hex shank bullnose 	1 1/4"	9	7/16-20	1/2-20	TW-9B
5/8" hex shank bullnose 	1 1/4"	12	5/8-18	3/4-16	TW-12B
	2 1/2"	13	3/4-16	7/8-14	TW-13B
3/4" hex shank bullnose 	3"	14	7/8-14	1-12	TW-14B
	3"	15	1/2	—	TW-15B



HI-TORQUE® DRIVER

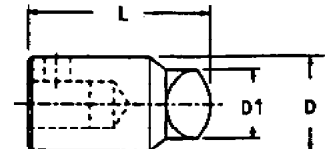
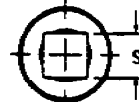
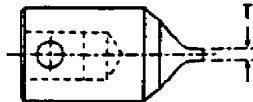





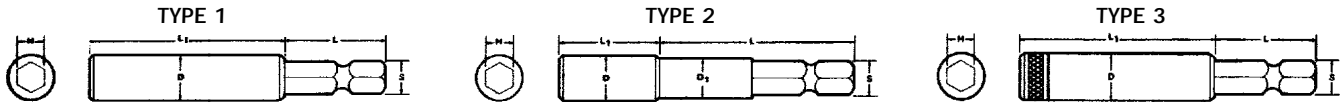
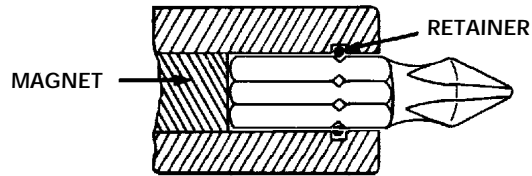

DRIVE S	RECESS	NOM. SCREW SIZE	T	D ₁	D	L	NATIONAL STOCK NO.*	ZEPHYR PART NO.
1/4"	1	3,4,5,6	.049"	.274"	1/2"	1"	5120-00-797-2992	ZHTS-1
1/4"	2	8	.059"	.295"	1/2"	1"	5120-00-863-4944	ZHTS-2
1/4"	3	10	.059"	.377"	1/2"	1"	5120-00-797-2994	ZHTS-3
1/4"	4	1/4	.073"	.502"	1/2"	1"	5120-00-863-4943	ZHTS-4
3/8"	4	1/4	.073"	.502"	1/2"	1"	5120-00-863-4942	ZHTS-4A
3/8"	5	5/16	.079"	.629"	3/4"	1 1/4"	5120-00-863-4941	ZHTS-5
3/8"	6	3/8	.095"	.745"	3/4"	1 1/4"	5120-00-863-4940	ZHTS-6
1/2"	7	7/16	.112"	.884"	1"	1 5/8"	5120-00-863-4945	ZHTS-7
1/2"	8	1/2	.142"	.995"	1"	1 5/8"	5120-00-937-8481	ZHTS-8

*Conforms to MS33750.

INSERT BIT HOLDERS HEX SHANK TO FEMALE HEX

MAGNETIC HOLDER
RETAINING RING DETAIL



ZEPHYR PART NO.	S HEX	H	D	D ₁	L	L ₁	
ZM10	1/4"	1/4"	7/16"	—	1"	1 7/8"	magnetic type 1 
ZM18	7/16"	1/4"	1/2"	—	1 1/4"	1 7/8"	
ZM19	5/16"	1/4"	7/16"	—	1 1/8"	1 7/8"	
ZM20	5/16"	5/16"	1/2"	—	1 1/8"	1 31/32"	
ZM39	1/4"	1/4"	7/16"	—	1"	1 1/4"	
ZM47	1/4"	5/16"	1/2"	—	1 1/16"	2 1/8"	
ZM59	1/4"	1/4"	3/8"	—	1"	1 7/8"	
ZM10-L 4	1/4"	1/4"	7/16"	5/16"	2 1/8"	1 7/8"	magnetic type 2 
ZM10-L 6	1/4"	1/4"	7/16"	5/16"	4 1/8"	1 7/8"	
ZM10-L 8	1/4"	1/4"	7/16"	5/16"	6 1/8"	1 7/8"	
ZM10-L 10	1/4"	1/4"	7/16"	5/16"	8 1/8"	1 7/8"	
ZM35	1/4"	1/4"	7/16"	3/8"	1"	1 7/8"	
ZM38	1/4"	1/4"	7/16"	3/8"	1 1/8"	1 7/8"	
ZM60	1/4"	1/4"	7/16"	—	1"	2 3/32"	magnetic type 3 
ZM62	1/4"	1/4"	7/16"	—	1"	1 1/4"	
ZM80	1/4"	1/4"	3/8"	—	1"	1 3/8"	2-pc magnetic type 1 
ZM81	1/4"	1/4"	7/16"	—	1 1/8"	1 7/8"	
ZNM19	5/16"	1/4"	7/16"	—	1 1/8"	3/4"	non-magnetic type 1 
ZNM20	5/16"	5/16"	1/2"	—	1 1/8"	1 3/8"	
ZNM28	7/16"	5/16"	9/16"	—	1 1/4"	1 1/2"	
ZNM10	1/4"	1/4"	7/16"	9/32"	1 1/8"	5/8"	non-magnetic type 2 
ZNM10-L 4	1/4"	1/4"	7/16"	5/16"	3"	1"	
ZNM10-L 6	1/4"	1/4"	7/16"	5/16"	5"	1"	
ZNM10-L 8	1/4"	1/4"	7/16"	5/16"	7"	1"	
ZNM10-L 10	1/4"	1/4"	7/16"	5/16"	9"	1"	



INSERT BIT HOLDERS THREADED DRIVE TO FEMALE HEX

ZEPHYR PART NO.	T	H	D	OVERALL LENGTH	TYPE	
ZM45	3/8"-24 R.H.	1/4"	3/8"	1 7/8"	Replaceable Cap	magnetic 
ZM41	3/8"-24 R.H.	1/4"	3/8"	1 7/8"	Solid Body	

INSERT BIT HOLDERS

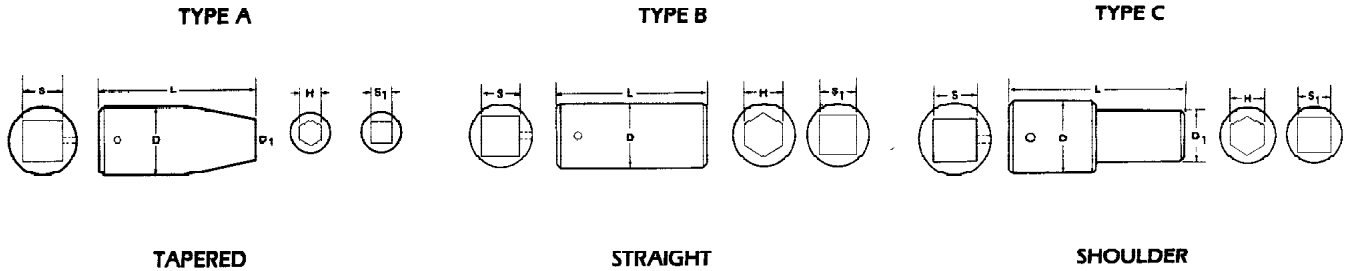

FEMALE SQUARE DRIVE TO FEMALE HEX OR SQUARE





	ZEPHYR PART NO.	DRIVE S	SQUARE S ₁	HEX H	D	D ₁	L
non-magnetic type A 	ZNM25	3/8" SQ.	—	1/4"	11/16"	—	1 1/4"
	ZNM26	3/8" SQ.	—	5/16"	11/16"	—	1 1/2"
	ZNM27	1/2" SQ.	—	5/16"	15/16"	—	1 1/2"
	ZNM33	3/8" SQ.	5/16"	—	11/16"	5/8"	1 1/2"
	ZNM34	1/2" SQ.	5/16"	—	1"	5/8"	1 3/4"
ZNM37	1/2" SQ.	—	—	1/4"	15/16"	—	1 1/2"
non-magnetic type B 	ZNM23	1/4" SQ.	—	1/4"	7/16"	—	7/8"
magnetic type C 	ZM23	1/4" SQ.	—	1/4"	9/16"	7/16"	2 1/16"
	ZM25	3/8" SQ.	—	1/4"	11/16"	7/16"	2 1/16"
	ZM26	3/8" SQ.	—	5/16"	1 1/16"	1/2"	2 3/4"
	ZM37	1/2" SQ.	—	1/4"	15/16"	7/16"	2 3/4"

NUT SETTERS HEX SHANK DRIVE TO FEMALE HEX



ZEPHYR PART NO.	S HEX	H	D	L	
Z10MSH-1/4	1/4"	1/4"	7/16"	1 3/4"	magnetic type 1 power 
Z10MSH-5/16	1/4"	5/16"	1/2"	1 3/4"	
Z10MSH-3/8	1/4"	3/8"	9/16"	1 3/4"	
Z10MSH-7/16	1/4"	7/16"	5/8"	1 3/4"	
Z10MSHL-1/4	1/4"	1/4"	7/16"	2 9/16"	
Z10MSHL-5/16	1/4"	5/16"	1/2"	2 9/16"	
Z10MSHL-3/8	1/4"	3/8"	9/16"	2 9/16"	
Z10MSHL-7/16	1/4"	7/16"	5/8"	2 9/16"	
Z10MSHS-1/4	1/4"	1/4"	7/16"	1 1/8"	magnetic type 2 insert 
Z10MSHS-5/16	1/4"	5/16"	1/2"	1 1/8"	
Z10MSHS-3/8	1/4"	3/8"	1/2"	1 1/8"	
Z10SH-1/4	1/4"	1/4"	7/16"	1 3/4"	non-magnetic type 1 power 
Z10SH-5/16	1/4"	5/16"	1/2"	1 3/4"	
Z10SH-3/8	1/4"	3/8"	9/16"	1 3/4"	
Z10SHL-1/4	1/4"	1/4"	7/16"	2 9/16"	
Z10SHL-5/16	1/4"	5/16"	1/2"	2 9/16"	
Z10SHL-3/8	1/4"	3/8"	9/16"	2 9/16"	

METRIC NUT SETTERS HEX SHANK TO FEMALE HEX

ZEPHYR PART NO.	S HEX	H MM	D MM	D IN. (REF.)	L MM	L IN. (REF.)	
Z10MSHL-5.5 MM	1/4"	5,5	10	3/8"	65	2 9/16"	magnetic type 1 
Z10MSHL-6 MM	1/4"	6	11	13/32"	65	2 9/16"	
Z10MSHL-7 MM	1/4"	7	11	13/32"	65	2 9/16"	
Z10MSHL-8 MM	1/4"	8	13	1/2"	65	2 9/16"	
Z10MSHL-9 MM	1/4"	9	14	17/32"	65	2 9/16"	
Z10MSHL-10 MM	1/4"	10	14	17/32"	65	2 9/16"	
Z10SHL-5.5 MM	1/4"	5,5	10	3/8"	65	2 9/16"	non-magnetic type 1 
Z10SHL-6 MM	1/4"	6	11	13/32"	65	2 9/16"	
Z10SHL-7 MM	1/4"	7	11	13/32"	65	2 9/16"	
Z10SHL-8 MM	1/4"	8	13	1/2"	65	2 9/16"	
Z10SHL-9 MM	1/4"	9	14	17/32"	65	2 9/16"	
Z10SHL-10 MM	1/4"	10	14	17/32"	65	2 9/16"	
Z10SHL-13 MM	1/4"	13	17	49/64"	65	2 9/16"	

SQUARE DRIVE SOCKETS FOR HEX HEAD SCREWS OR NUTS

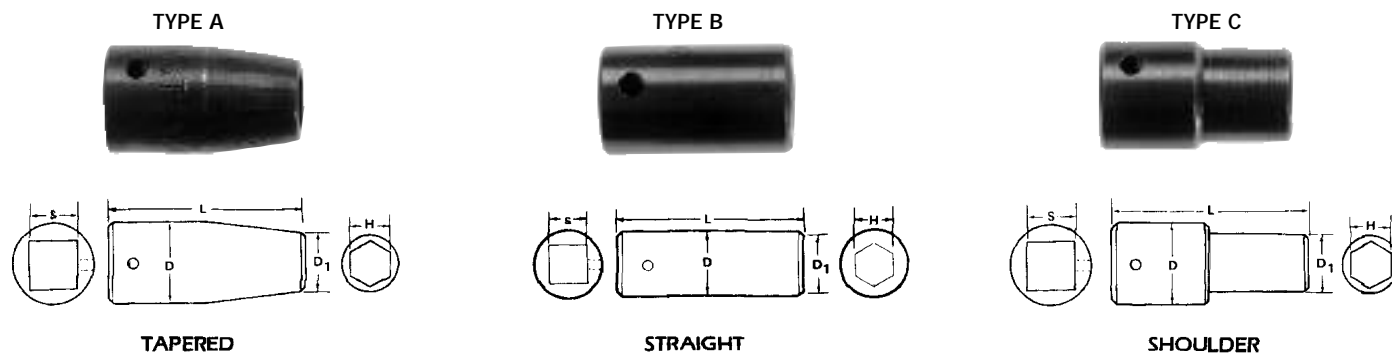

1/4" SQUARE DRIVE SOCKETS

	ZEPHYR PART NO.	H	D	D ₁	L	S	TYPE
magnetic	Z48MST-1/4	1/4"	1/2"	3/8"	7/8"	1/4"	A
	Z48MS-1/4	1/4"	1/2"	7/16"	7/8"	1/4"	C
	Z48MS-5/16	5/16"	1/2"	1/2"	7/8"	1/4"	B
	Z48MST-5/16	5/16"	1/2"	7/16"	7/8"	1/4"	A
	Z48MS-3/8	3/8"	9/16"	9/16"	1"	1/4"	B
	Z48MS-7/16	7/16"	3/4"	3/4"	1"	1/4"	B
non-magnetic	Z48S-1/4	1/4"	1/2"	7/16"	7/8"	1/4"	C
	Z48ST-1/4	1/4"	1/2"	3/8"	7/8"	1/4"	A
	Z48S-5/16	5/16"	1/2"	1/2"	7/8"	1/4"	B
	Z48S-3/8	3/8"	9/16"	9/16"	1"	1/4"	B
	Z48S-7/16	7/16"	3/4"	3/4"	1"	1/4"	B

SQUARE DRIVE SOCKETS FOR HEX HEAD SCREWS OR NUTS

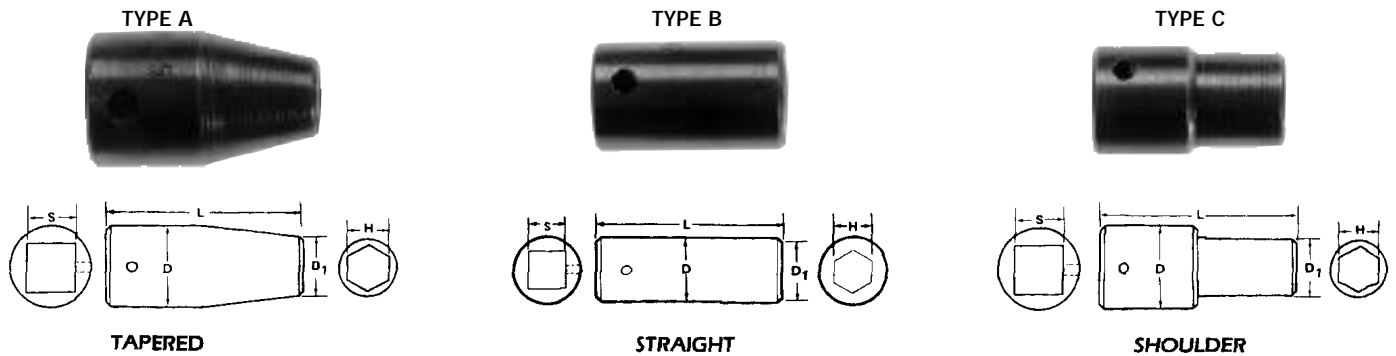

3/8" SQUARE DRIVE SOCKETS

ZEPHYR PART NO.	H	D	D ₁	L	S	TYPE	
Z50MST-1/4	1/4"	3/4"	3/8"	1 1/4"	3/8"	A	magnetic
Z50MST-5/16	5/16"	3/4"	1/2"	1 1/4"	3/8"	A	
Z50MST-3/8	3/8"	3/4"	5/8"	1 1/4"	3/8"	A	
Z50MS-7/16	7/16"	3/4"	3/4"	1 1/4"	3/8"	B	
Z50MS-1/2	1/2"	3/4"	3/4"	1 1/4"	3/8"	B	
Z50ST-1/4	1/4"	3/4"	7/16"	1 1/4"	3/8"	A	non-magnetic
Z50ST-5/16	5/16"	3/4"	1/2"	1 1/4"	3/8"	A	
Z50ST-3/8	3/8"	3/4"	5/8"	1 1/4"	3/8"	A	
Z50S-1/2	1/2"	3/4"	3/4"	1 1/4"	3/8"	B	
Z50S-9/16	9/16"	15/16"	15/16"	1 1/4"	3/8"	B	

1/2" SQUARE DRIVE SOCKETS







ZEPHYR PART NO.	H	D	D ₁	L	S	TYPE	
Z51MST-1/4	1/4"	15/16"	7/16"	1 1/2"	1/2"	A	magnetic
Z51MST-5/16	5/16"	15/16"	1/2"	1 1/2"	1/2"	A	
Z51MST-3/8	3/8"	15/16"	5/8"	1 1/2"	1/2"	A	
Z51MST-7/16	7/16"	15/16"	1 1/16"	1 1/2"	1/2"	A	
Z51MST-1/2	1/2"	15/16"	3/4"	1 1/2"	1/2"	A	
Z51MS-1/2	1/2"	15/16"	15/16"	1 1/2"	1/2"	B	non-magnetic
Z51MS-9/16	9/16"	15/16"	15/16"	1 1/2"	1/2"	B	
Z51ST-1/2	1/2"	15/16"	3/4"	1 1/2"	1/2"	A	
Z51ST-9/16	9/16"	15/16"	13/16"	1 1/2"	1/2"	A	
Z51S-1/2	1/2"	15/16"	15/16"	1 1/2"	1/2"	B	
Z51S-9/16	9/16"	15/16"	15/16"	1 1/2"	1/2"	B	

1/4" REVERSIBLE SOCKETS FOR HEX HEAD SHEET METAL FASTENERS

ZEPHYR PART NO.	H	D	L	TYPE	
Z10RSR-1/4	1/4"	3/8"	1"	B	magnetic
Z10RS-1/4	1/4"	7/16"	1"	B	

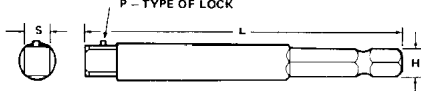

EXTENSIONS HEX SHANK DRIVE TO MALE SQUARE

	ZEPHYR PART NO.	S	H	L	P
1/4" hex to 1/4" square	Z10SH-1B	1/4"	1/4"	1"	BALL
					
1/4" hex to 1/4" square	Z10SH- 1 3/8	1/4"	1/4"	1 3/8"	PIN
	Z10SH- 2	1/4"	1/4"	2"	PIN
	Z10SH- 3	1/4"	1/4"	3"	PIN
	Z10SH- 4	1/4"	1/4"	4"	PIN
	Z10SH- 5	1/4"	1/4"	5"	PIN
	Z10SH- 6	1/4"	1/4"	6"	PIN
	Z10SH- 8	1/4"	1/4"	8"	PIN
	Z10SH-10	1/4"	1/4"	10"	PIN
	Z10SH-12	1/4"	1/4"	12"	PIN
1/4" hex to 3/8" square	Z10SH-3/8-2	3/8"	1/4"	2"	PIN
	Z10SH-3/8-3	3/8"	1/4"	3"	PIN
	Z10SH-3/8-4	3/8"	1/4"	4"	PIN
	Z10SH-3/8-6	3/8"	1/4"	6"	PIN
	Z10SH-3/8-8	3/8"	1/4"	8"	PIN
7/16" hex to 3/8" square	Z09SH-3/8	3/8"	7/16"	1 3/4"	PIN
	Z09SH-3/8- 2	3/8"	7/16"	2"	PIN
	Z09SH-3/8- 3	3/8"	7/16"	3"	PIN
	Z09SH-3/8- 4	3/8"	7/16"	4"	PIN
	Z09SH-3/8- 5	3/8"	7/16"	5"	PIN
	Z09SH-3/8- 6	3/8"	7/16"	6"	PIN
	Z09SH-3/8- 8	3/8"	7/16"	8"	PIN
	Z09SH-3/8-10	3/8"	7/16"	10"	PIN
	Z09SH-3/8-12	3/8"	7/16"	12"	PIN
7/16" hex to 1/2" square	Z09SH-1/2	1/2"	7/16"	2 1/8"	PIN
	Z09SH-1/2- 3	1/2"	7/16"	3"	PIN
	Z09SH-1/2- 4	1/2"	7/16"	4"	PIN
	Z09SH-1/2- 5	1/2"	7/16"	6"	PIN
	Z09SH-1/2- 6	1/2"	7/16"	6"	PIN
	Z09SH-1/2- 8	1/2"	7/16"	8"	PIN

Note: Zephyr extensions available with ball retainer on special request.

EXTENSIONS HEX SHANK TO MALE HEX (Reversible Sockets)

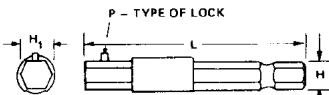
	ZEPHYR PART NO.	H	H ₁	L	P
1/4" hex to 1/4" hex	Z10SHR-2	1/4"	1/4"	2"	PIN
	Z10SHR-3	1/4"	1/4"	3"	PIN
	Z10SHR-4	1/4"	1/4"	4"	PIN

HAND BIT HOLDERS COMBINATION HOLDER WITH BIT STORAGE

BIT SIZE	D	L ₁	L ₂	SHANK MATERIAL	ZEPHYR PART NO.	
1/4" HEX	3/8"	7 ¹³ / ₁₆ "	3 ³ / ₄ "	ALUMINUM	H104MA	magnetic
1/4" HEX	3/8"	7 ¹³ / ₁₆ "	3 ³ / ₄ "	S. STEEL	H104MS	
5/16" HEX	7/16"	7 ¹³ / ₁₆ "	3 ³ / ₄ "	ALUMINUM	H105MA	
5/16" HEX	7/16"	7 ¹³ / ₁₆ "	3 ³ / ₄ "	S. STEEL	H105MS	
1/4" HEX	7/16"	7 ¹³ / ₁₆ "	3 ³ / ₄ "	STEEL	H104NM	non-magnetic
5/16" HEX	1/2"	7 ¹³ / ₁₆ "	3 ³ / ₄ "	STEEL	H105NM	

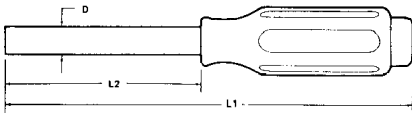

Note: Bit storage handle will accommodate up to four 1/4" Hex 1" insert bits.

HAND BIT HOLDERS STUBBY HOLDER WITH SOLID HANDLE

BIT SIZE	D	L ₁	L ₂	SHANK MATERIAL	ZEPHYR PART NO.	
1/4" HEX	3/8"	3 ⁵ / ₈ "	1 ⁵ / ₈ "	S. STEEL	SH104M	magnetic
1/4" HEX	7/16"	3 ⁵ / ₈ "	1 ⁵ / ₈ "	STEEL	SH104NM	non-magnetic

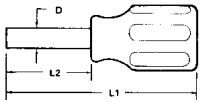

HAND BIT HOLDERS SOLID HANDLE

BIT SIZE	D	L ₁	L ₂	SHANK MATERIAL	ZEPHYR PART NO.	
1/4" HEX	3/8"	8 ¹ / ₄ "	3 ³ / ₄ "	ALUMINUM	H106MA	magnetic
1/4" HEX	3/8"	8 ¹ / ₄ "	3 ³ / ₄ "	S. STEEL	H106MS	
5/16" HEX	7/16"	8 ¹ / ₄ "	3 ³ / ₄ "	ALUMINUM	H107MA	
5/16" HEX	7/16"	8 ¹ / ₄ "	3 ³ / ₄ "	S. STEEL	H107MS	
1/4" HEX	7/16"	8 ¹ / ₄ "	3 ³ / ₄ "	STEEL	H106NM	non-magnetic
5/16" HEX	1/2"	8 ¹ / ₄ "	3 ³ / ₄ "	STEEL	H107NM	

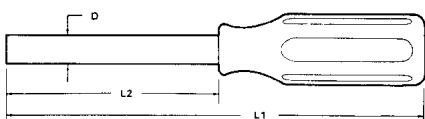



HAND SCREWDRIVERS ACR®-PHILLIPS

POINT SIZE	D	L ₁	L ₁	ZEPHYR PART NO. REMOVAL
1	1/4" HEX	7 1/16"	3 1/8"	PL101ACR-B
2	1/4" HEX	8 1/2"	4"	PL102ACR-B
3	5/16" HEX	10 1/2"	6"	PL103ACR-B

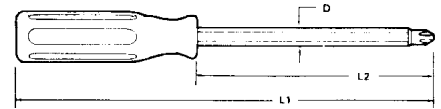

ACR® is a Registered Trademark of the Phillips Screw Company



HAND SCREWDRIVERS POZIDRIV®

POINT SIZE	D	L ₁	L ₂	ZEPHYR PART NO.
0	1/4" HEX	7 1/16"	3 1/8"	PZ101P-0
1	1/4" HEX	7 1/16"	3 1/8"	PZ101P-1
2	1/4" HEX	8 1/2"	4"	PZ101P-2
3	5/16" HEX	10 1/2"	6"	PZ101P-3
4	5/16" HEX	12 5/8"	8 1/8"	PZ101P-4

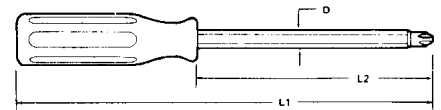

POZIDRIV® is a Registered Trademark of the Phillips Screw Company

Note: Zephyr hand screwdrivers and bit holders are offered with plastic handles, which are shock proof and non-flammable. These handles are deep fluted for grip and turning power.

The shanks are produced from the same high quality steel, under the strict quality controls that go into the production of Zephyr insert and power screwdriver bits.

HAND SCREWDRIVERS TORQ-SET®



POINT SIZE	D	L ₁	L ₂	ZEPHYR PART NO.
0	1/4" HEX	3"	1 1/4"	TS201P-0
1	1/4" HEX	3"	1 1/4"	TS201P-1
2	1/4" HEX	7 1/16"	3 1/8"	TS201P-2
3	1/4" HEX	7 1/16"	3 1/8"	TS201P-3
4	1/4" HEX	7 1/16"	3 1/8"	TS201P-4
5	1/4" HEX	7 1/16"	3 1/8"	TS201P-5
6	1/4" HEX	7 15/16"	4"	TS201P-6
8	1/4" HEX	7 15/16"	4"	TS201P-8
10	1/4" HEX	7 15/16"	4"	TS201P-10
1/4	5/16" HEX	10 1/2"	6"	TS201P-1/4
5/16	3/8" HEX	12 1/2"	8"	TS201P-5/16
3/8	3/8" HEX	12 1/2"	8"	TS201P-3/8

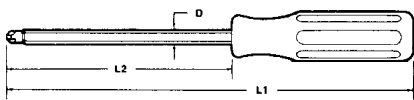

TORQ-SET® is a Registered Trademark of the Phillips Screw Company

HAND SCREWDRIVERS TRI-WING®



POINT SIZE	D	L ₁	L ₂	ZEPHYR PART NO.
0	1/4" HEX	3"	1 1/4"	TW301P-0
1	1/4" HEX	3"	1 1/4"	TW301P-1
2	1/4" HEX	7 1/16"	3 1/8"	TW301P-2
3	1/4" HEX	7 15/16"	4"	TW301P-3
4	1/4" HEX	7 15/16"	4"	TW301P-4
5	1/4" HEX	7 15/16"	4"	TW301P-5
6	3/8" HEX	10 1/2"	6"	TW301P-6
7	3/8" HEX	12 1/2"	8"	TW301P-7

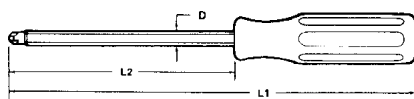

TRI-WING® is a Registered Trademark of the Phillips Screw Company

NATIONAL STOCK NUMBER TO ZEPHYR PART NUMBER

NSN NUMBER	ZEPHYR	NSN NUMBER	ZEPHYR
5120-00-033-9035	TS201P-2	5120-01-168-9571	Z0T27X
5120-00-082-8529	TS212-2	5120-01-180-8940	Z0T10X
5120-00-204-0985	H5239A	5130-00-021-2002	E3105A
5120-00-223-6971	D1221AA	5130-00-021-2003	E3104A
5120-00-223-6975	C223-3AA	5130-00-021-2015	E3101A
5120-00-223-6977	C222-2AA	5130-00-021-2016	E3100A
5120-00-226-5559	TS212-0	5130-00-021-2017	E3099A
5120-00-226-5560	TS212-1	5130-00-021-2018	E3098A
5120-00-226-5562	TS212-3	5130-00-021-2025	E1103AA
5120-00-226-5606	TS212-1/4B	5130-00-063-2738	TS170-7/16
5120-00-250-5576	D1223AA	5130-00-108-6268	D1222II2
5120-00-289-9453	H5222A	5130-00-177-6832	H5226A
5120-00-289-9454	H5221A	5130-00-226-5607	TS170-1/4A
5120-00-293-2048	5120002932048	5130-00-226-5604	TS170-8A
5120-00-293-2057	H53221A	5130-00-226-5605	TS170-10A
5120-00-515-2814	TS212-3/8AB	5130-00-226-5606	TS170-1/4B
5120-00-595-8197	D1222AA	5130-00-226-5608	TS170-5/16B
5120-00-595-8198	D1234AA	5130-00-226-5609	TS170-5/16A
5120-00-596-2893	D1232AA	5130-00-226-5610	TS170-3/8B
5120-00-640-6725	H5223A	5130-00-226-5611	TS170-3/8A
5120-00-640-6728	H5238A	5130-00-240-5250	D1253AA
5120-00-640-6729	H5220A	5130-00-240-5251	D1254AA
5120-00-640-6730	H5229A	5130-00-337-9125	ZNM10
5120-00-640-6731	H5228A	5130-00-511-0207	TS170-9/16
5120-00-640-6732	H5227A	5130-00-511-0208	TS170-1/2
5120-00-640-6733	H5225A	5130-00-511-0210	TS170-3/8
5120-00-674-9215	TS201P-10	5130-00-529-4944	E1093AA35
5120-00-674-9216	TS201P-8	5130-00-624-7973	TS170-5/8
5120-00-675-0867	TS201P-6	5130-00-672-8671	TS170-1/4R
5120-00-714-7400	TS201P-4	5130-00-672-8679	TS170-5/16BR
5120-00-756-2209	TS212-5	5130-00-674-9211	TS265-6-35
5120-00-888-5826	TS212-8	5130-00-674-9212	TS265-8-35
5120-00-888-5827	TS212-6	5130-00-674-9213	TS265-10-35
5120-00-888-5828	TS212-5/16AB	5130-00-690-7259	E1102XXR
5120-00-888-5829	TS212-4	5130-00-724-3703	TS265-4-35
5120-00-888-5831	TS212-10	5130-00-726-7873	TS170-8R
5120-00-921-0574	H5224A	5130-00-774-7130	TS170-10R
5120-00-957-3653	D1220AA	5130-00-798-0825	TS170-2
5120-01-168-1135	Z0T20X	5130-00-798-0826	TS170-3
5120-01-168-1136	Z0T25X	5130-00-798-0828	TS170-4
5120-01-168-1137	Z0T30X	5130-00-798-0829	TS170-5
5120-01-168-9570	Z0T15X	5130-00-805-3793	TS170-6R

NOTES

NOTES



TABLE OF SCREW SIZES SLOTTED HEAD STYLE

SLOTTED HEAD STYLE

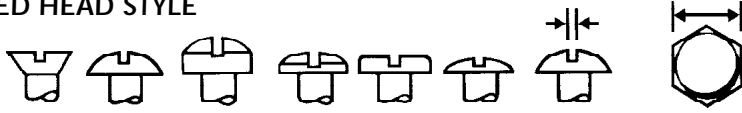

MAXIMUM HEAD DIAMETER

SCREW SIZE	THREAD DIA.	FLAT OR OVAL HEAD	ROUND HEAD	FILLISTER HEAD	BINDING HEAD	PAN HEAD	TRUSS HEAD	SLOT WIDTH MIN.	SLOT WIDTH MAX.	HEX HEAD ACROSS FLATS
2	.086	.172	.162	.140	.181	.167	.194	.023	.031	
3	.099	.199	.187	.161	.208	.193	.226	.027	.035	
4	.112	.225	.211	.183	.235	.219	.257	.031	.039	.187
5	.125	.252	.236	.205	.263	.245	.289	.035	.043	.187
6	.138	.279	.260	.226	.290	.270	.321	.039	.048	.250
8	.164	.332	.309	.270	.344	.322	.384	.045	.054	.250
10	.190	.385	.359	.313	.399	.373	.448	.050	.060	.312
12	.216	.438	.408	.357	.454	.425	.511	.056	.067	.312
¼	.250	.507	.472	.414	.513	.492	.573	.064	.075	.375
⅝	.310	.635	.590	.518	.641	.615	.698	.072	.084	.500
¾	.370	.762	.708	.622	.769	.740	.823	.081	.094	.562

Note: All dimensions are given in inches.



PHILLIPS HEAD STYLE

PHILLIPS HEAD STYLE



MAXIMUM HEAD DIAMETER

Point Size	Body Diam.	WOOD SCREW SIZE		MACHINE SCREW SIZE			SHEET METAL SCREWS
		Flat Oval	Round	Flat Oval Binding	Round Fillister	Truss Brazier Button	Flat, Round, Oval, Stove, Binding
0		No. 0 & 1	No. 0 & 1	No. 0 & 1	No. 0 & 1	No. 0 & 1	No. 0 & 1
1	⅜	2, 3, 4	2, 3, 4	2, 3, 4	2, 3, 4	2, 3, 4	2, 3, 4
2	¼	5, 6, 7 8, 9	5, 6, 7 8, 9, 10	5, 6, 8 10	5, 6, 8 10	6, 8, 10	5, 6, 7 8, 10
3	⅝	10, 12 14, 16	12, 14 16	12, ¼	12, ¼ ⅝	12, ¼	12, 14
4	¾	18, 20 24	18, 20 24	⅝, ¾, 7/16, ½	¾, 7/16, ½	⅝, ¾, 7/16, ½	

IMPORTANT The table above will enable you to determine the Phillips point size required for any Phillips screws or bolts. The No. 2 and No. 3 point sizes cover the range of Phillips screws most commonly used.



ZEPHYR[®]
SCREWDRIVING TOOLS

Not For Sale
 **I·D·A**
The Industrial Distributors Association

