

# WELD SHAVER SPECIFICATIONS

**ZEPHYR**<sup>®</sup>  
MANUFACTURING COMPANY

## CUTTERS AND ATTACHMENTS

### CUTTERS FOR ZT 708

For use on Titanium, Stainless Steel, Monel and similar high strength materials.

CUTTER PART NUMBER	CUTTER MATERIAL	D DIAMETER	W WIDTH	CUTTER		ROLLER SHAFT ASSEMBLY	CUTTER ADJUSTMENT	
				STYLE	TYPE		IN	OUT
ZT508-20B	Carbide	1 1/2"	1/2"	Slab	I	ZT709041	.230"	.206"
ZT508-21B	Carbide	1 1/2"	3/4"	Slab	I	ZT709042	.230"	.206"
ZT508-22B	Carbide	1 1/2"	3/8"	Slab	I	ZT709040	.230"	.206"
ZT508-26B	Carbide	1 1/2"	1/2"	Slab	II	ZT709041	.230"	.206"
ZT508-27B	Carbide	1 1/2"	3/4"	Slab	II	ZT709042	.230"	.206"
ZT508-28B	Carbide	1 1/2"	3/8"	Slab	II	ZT709040	.230"	.206"
ZT508-29B	Carbide	1 1/2"	5/8"	Slab	II	ZT709098	.230"	.206"
ZT508-35B	Carbide	1 1/2"	3/8"	Slab	II	ZT709040	.230"	.206"
ZT508-36B	Carbide	1 1/2"	1/2"	Slab	II	ZT709041	.230"	.206"
ZT508-37B	Carbide	1 1/2"	3/4"	Slab	II	ZT709042	.230"	.206"
ZT508-38B	Carbide	1 1/2"	1 5/16"	Slab	II	ZT708031	.230"	.206"
ZT708-20B	Carbide	1 1/2"	1"	Slab	II	ZT709043	.230"	.206"

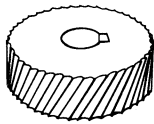

TYPE I slab cutter w/o chipbreaker

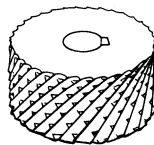

TYPE II slab cutter w/ chipbreaker

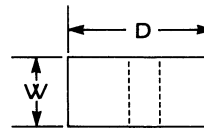

SLAB TYPE

### CUTTER FOR ZT 709

For use on Aluminum, Magnesium, Copper and softer alloys.

CUTTER NUMBER	CUTTER MATERIAL	D DIAMETER	W WIDTH	A ANGLE	CUTTER STYLE	R RADIUS	ROLLER SHAFT ASSEMBLY	CUTTER ADJUSTMENT	
								IN	OUT
ZT509-20	H.S.S.	1 1/2"	1/2"	—	Slab	—	ZT709041	.230"	.206"
ZT509-21	H.S.S.	1 1/2"	3/4"	—	Slab	—	ZT709042	.230"	.206"
ZT509-22B	Carbide	1 1/2"	1/2"	—	Slab	—	ZT709041	.230"	.206"
ZT509-23B	Carbide	1 1/2"	3/4"	—	Slab	—	ZT709042	.230"	.206"
ZT509-24	H.S.S.	1 1/2"	3/8"	—	Slab	—	ZT709040	.230"	.206"
ZT509-25B	Carbide	1 1/2"	3/8"	—	Slab	—	ZT709040	.230"	.206"
ZT509-32B	Carbide	1 1/2"	5/8"	—	Slab	—	ZT709098	.230"	.206"
ZT509-37B	Carbide	1 1/2"	1/2"	—	Slab	—	ZT709041	.230"	.206"
ZT509-38B	Carbide	1 1/2"	1"	—	Slab	—	ZT709043	.230"	.206"
ZT509-39B	Carbide	1 1/2"	3/4"	—	Slab	—	ZT709042	.230"	.206"
ZT509-33	H.S.S.	1 5/16"	1/2"	75°	Groove	.046	ZT709041	.046"	.420"
ZT509-36B	Carbide tip	1.906"	1/2"	60°	Groove	.062	ZT709041	.015"	.409"
ZT509-45B	Carbide tip	1.687"	1/2"	88°	Groove	.062	ZT709041	.137"	.299"



SLAB TYPE

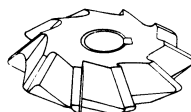
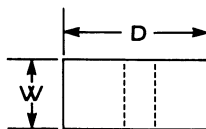

GROOVING TYPE

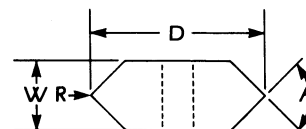

Form cutters upon request only.

# OUTRIGGER ATTACHMENT FOR ZT708/ZT709

Specify ZT7090160 for right hand cutting. Specify ZT7090170 for left hand cutting.

WELD SHAVER NUMBER	OUTRIGGER ATTACHMENT NUMBER	STANDARD CUTTER NUMBER	RECESSED FLUSH CUTTER FLUSH	RECESSED RADIUS FLUSH CUTTER	CUTTER RADIUS	ROLLER BRACKET NEEDED*
ZT708	ZT7090160	ZT508-21B ZT508-27B ZT508-37B	ZT708-21B	ZT708-23B	.250	ZT709046 ZT709046 ZT709046
	RIGHT HAND					
ZT708	ZT7090170	ZT508-21B ZT508-27B ZT508-37B	ZT708-22B	ZT708-24B	.250	ZT709046 ZT709046 ZT709046
	LEFT HAND					
ZT709	ZT7090160	ZT509-21 ZT509-23B ZT509-39B	ZT709-20B	ZT709-21B	.250	ZT709046 ZT709046 ZT709046
	RIGHT HAND					
ZT709	ZT7090170	ZT509-21 ZT509-23B ZT509-39B	ZT709-22B	ZT709-23B	.250	ZT709046 ZT709046 ZT709046
	LEFT HAND					

\*Recommended for stability if your ZT708 or ZT709 does not have 3/4" wide roller bracket.

# BEVEL ATTACHMENTS FOR ZT708/ZT709

WELD SHAVER NUMBER	BEVEL ATTACHMENT NUMBER 60°	CUTTER NUMBER	STYLE
ZT708	ZT7090150 ZT7090151	ZT708-20B ZT708-20B	RIGHT HAND LEFT HAND
ZT709	ZT7090150 ZT7090151	ZT509-38B ZT509-38B	RIGHT HAND LEFT HAND

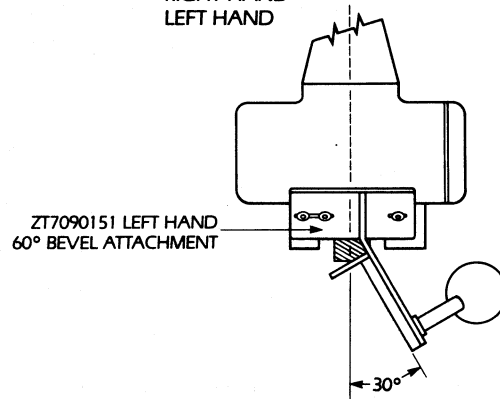
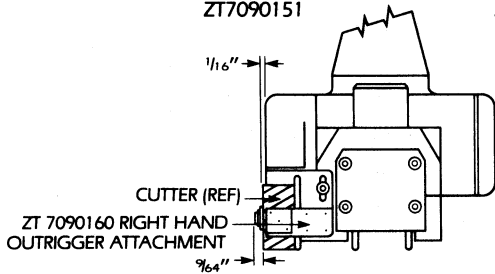

# DIMENSIONS AND SPECIFICATIONS OF WELD SHAVERS

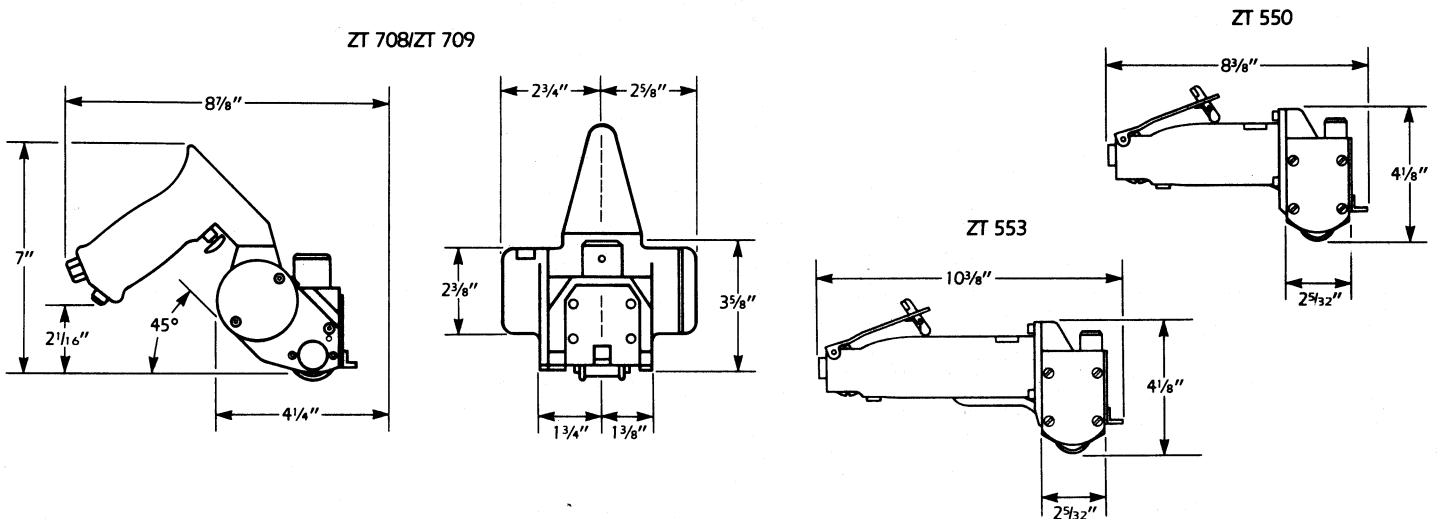

# CUTTERS FOR ZT550

For use on Aluminum, Magnesium, Copper and softer alloys.

CUTTER NUMBER	CUTTER MATERIAL	D DIAMETER	W WIDTH	A ANGLE	CUTTER STYLE	R RADIUS	ROLLER SHAFT ASSEMBLY	CUTTER ADJUSTMENT	
								IN	OUT
ZT550-21	H.S.S.	1 1/8"	3/8"	—	Slab	—	ZT550069	.125"	.187"
ZT550-23	H.S.S.	1 1/8"	1/2"	—	Slab	—	ZT550070	.125"	.187"
ZT550-30	Carbide	1 1/8"	1/4"	—	Slab	—	ZT550069	.125"	.187"
ZT550-31	Carbide	1 1/8"	3/8"	—	Slab	—	ZT550069	.125"	.187"
ZT550-32	Carbide	1 1/8"	1/2"	—	Slab	—	ZT550070	.125"	.187"
ZT550-29	H.S.S.	1 5/16"	3/8"	60°	Groove	.062	ZT550069	.000"	.234"
ZT550-40	H.S.S.	1 3/16"	3/8"	40°	Groove	.062	ZT550069	.086"	.320"
ZT550-41	H.S.S.	1 5/16"	3/8"	40°	Groove	.062	ZT550069	.000"	.234"

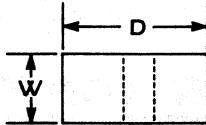
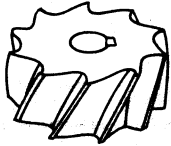

SLAB TYPE

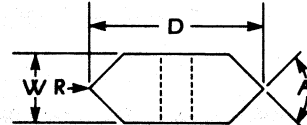

GROOVING TYPE

# CUTTERS FOR ZT553

For use on Titanium, Stainless Steel, Monel and similar high strength materials.

CUTTER NUMBER	CUTTER MATERIAL	D DIAMETER	W WIDTH	CUTTER STYLE	ROLLER SHAFT ASSEMBLY	CUTTER ADJUSTMENT	
						IN	OUT
ZT553-26	Carbide	1 1/8"	1/2"	Slab	ZT550070	.125"	.187"
ZT553-28	Carbide	1 1/8"	3/8"	Slab	ZT550069	.125"	.187"

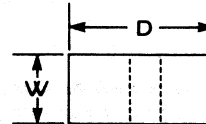
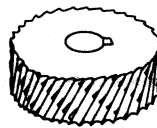

SLAB TYPE

ZT 551/ZT 552 ZT 554/ZT 555

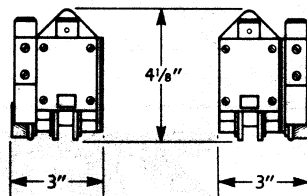
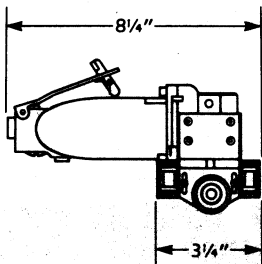

ZT 501

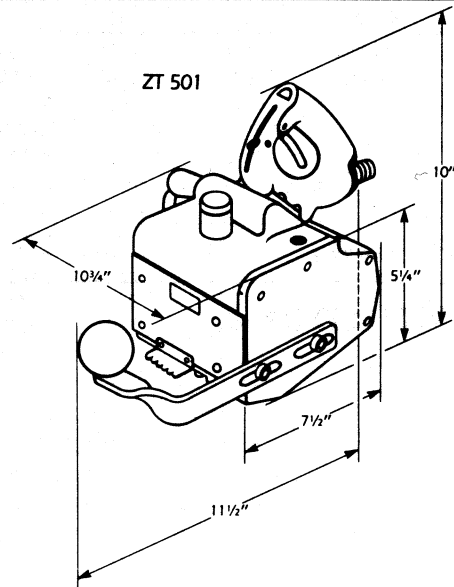

	ZT708	ZT709	ZT550	ZT553	ZT501
CUTTER ROTATION (RPM)	2,700	13,500	15,000	3,500	4,600
WEIGHT	6 lbs.	6 lbs.	3 3/4 lbs.	5 lbs.	25 lbs.
REQUIRED CFM (MIN.)	35	35	29	29	44
REQUIRED PSI (MIN.)	90	90	90	90	90

## CUTTERS FOR ZT551/ZT552

For use on Aluminum, Magnesium, Copper and softer alloys.

CUTTER NUMBER	CUTTER MATERIAL	D DIAMETER	W WIDTH	A ANGLE	CUTTER STYLE	R RADIUS	CUTTER ADJUSTMENT	
							IN	OUT
ZT551-30	Carbide	1 1/4"	1/2"	70°	Groove	.156	.078"	.218"
ZT551-31	H.S.S.	1 1/4"	1/2"	70°	Groove	.156	.078"	.218"
ZT551-32	Carbide	1 1/8"	1/2"	—	Slab	—	.125"	.187"
ZT552-32	Carbide	1 1/8"	1/2"	—	Slab	—	.125"	.187"
ZT552-30	Carbide	1 1/4"	1/2"	70°	Groove	.156	.078"	.187"

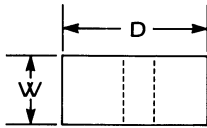
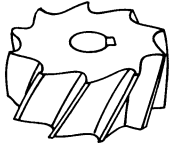

SLAB TYPE

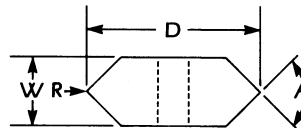

GROOVING TYPE

## CUTTERS FOR ZT554/ZT555

For use on Titanium, Stainless Steel, Monel and similar high strength materials.

CUTTER NUMBER	RADIUS CUTTER NUMBER	CUTTER MATERIAL	CUTTER RADIUS	D DIAMETER	W WIDTH	CUTTER STYLE	CUTTER ADJUSTMENT	
							IN	OUT
ZT554-31B		Carbide	—	1 1/8"	1/2"	Slab	.125"	.187"
	ZT554-30	Carbide	.250	1 3/8"	1/2"	Slab	.250"	.062"
ZT555-31B		Carbide	—	1 1/8"	1/2"	Slab	.125"	.187"
	ZT555-30	Carbide	.250	1 3/8"	1/2"	Slab	.250"	.062"

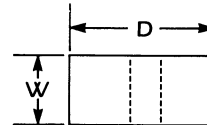
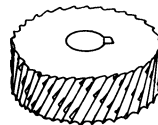

SLAB TYPE

## CUTTERS FOR ZT 501

For use on Aluminum, Magnesium, Copper and softer alloys.

CUTTER NUMBER	CUTTER MATERIAL	D DIAMETER	W WIDTH	A ANGLE	CUTTER STYLE	R RADIUS	ROLLER SHAFT ASSEMBLY	CUTTER ADJUSTMENT	
								IN	OUT
ZT501-19	Carbide	2"	3/4"	—	Slab	—	ZT5010124	-.240"	+.240"
ZT501-20	Carbide	2"	1"	—	Slab	—	ZT5010121	-.240"	+.240"
ZT501-21	Carbide	2"	1 1/2"	—	Slab	—	ZT5010122	-.240"	+.240"
ZT501-22	Carbide	2"	2"	—	Slab	—	ZT5010123	-.240"	+.240"
ZT501-30	Carbide	3 3/8"	1 1/2"	60°	Groove	.156"	ZT5010126	.000"	1.06"
ZT501-31	Carbide	3 3/8"	1 3/8"	70°	Groove	.156"	ZT5010128	.000"	1.06"

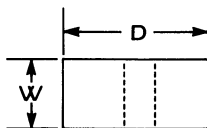
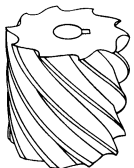

SLAB TYPE

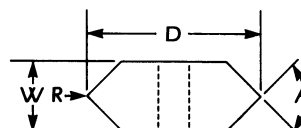
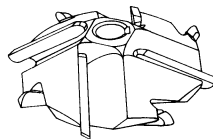

GROOVING TYPE

REPRESENTED BY

# ZEPHYR<sup>®</sup>

MANUFACTURING COMPANY

201 Hindry Ave.  
P.O. Box 759  
Inglewood, CA 90307  
(213) 776-7600  
Fax (310) 410-2913

Your first source



© Copyright 1988 Zephyr Manufacturing Co.

Printed in USA 2-96 3M

Zephyr<sup>®</sup> is a registered trademark of Zephyr Manufacturing Company.