

NIAGARA THERMAL PRODUCTS — LLC —

AIRCRAFT OIL COOLER P/N: 20006A

This Oil Cooler features lightweight vacuum brazed aluminum construction providing reliable service, efficient heat transfer and low pressure drop. All units have FAA-PMA and are proof pressure tested at 400 psig and leak tested at 100 psig. Corrosion protection is provided by MIL-C-5541 Class 1A chromicoat.

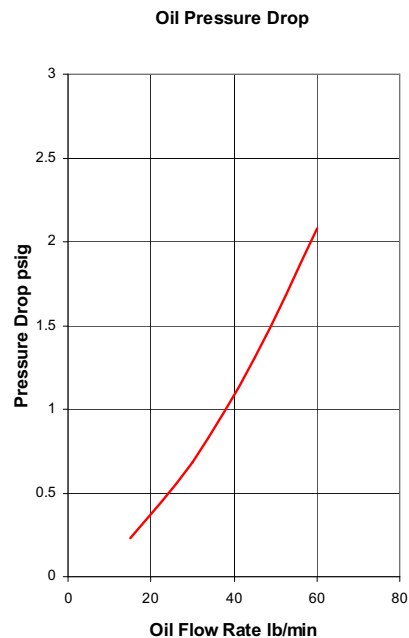
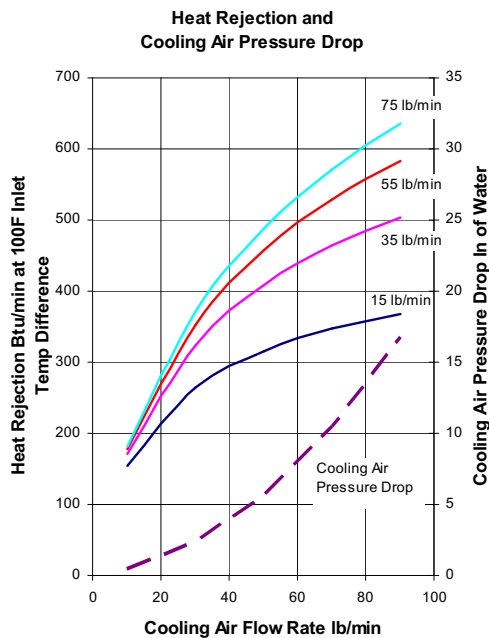
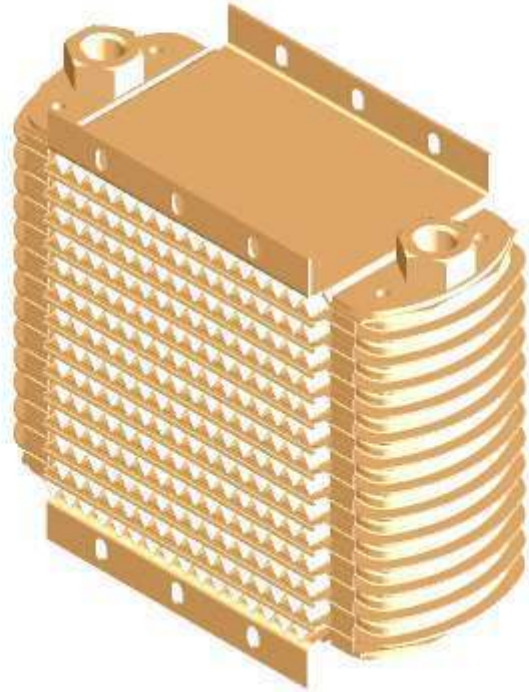

3315 Haseley Drive
Niagara Falls, New York USA 14304
(716) 297-0652 phone
(716) 297-2550 fax
www.niagarathermal.com
formerly known as THE NDM/KINTEX Co.

NIAGARA THERMAL PRODUCTS LLC

AIRCRAFT OIL COOLER P/N: 20006A

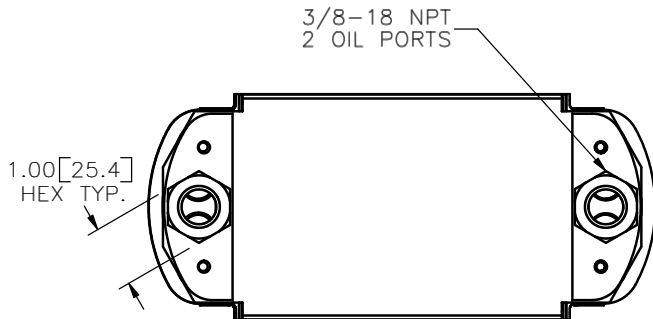

DIMENSIONS ARE SHOWN IN INCHES
w/ MILLIMETERS IN BRACKETS [].

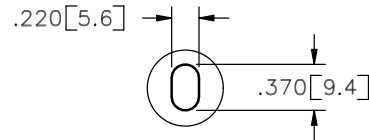

DETAIL A
MOUNTING SLOTS TYP.

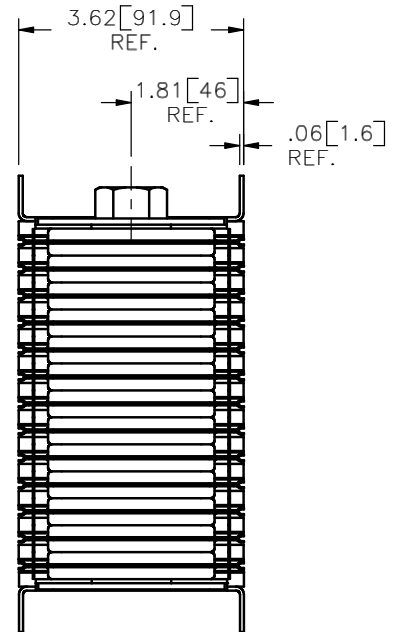
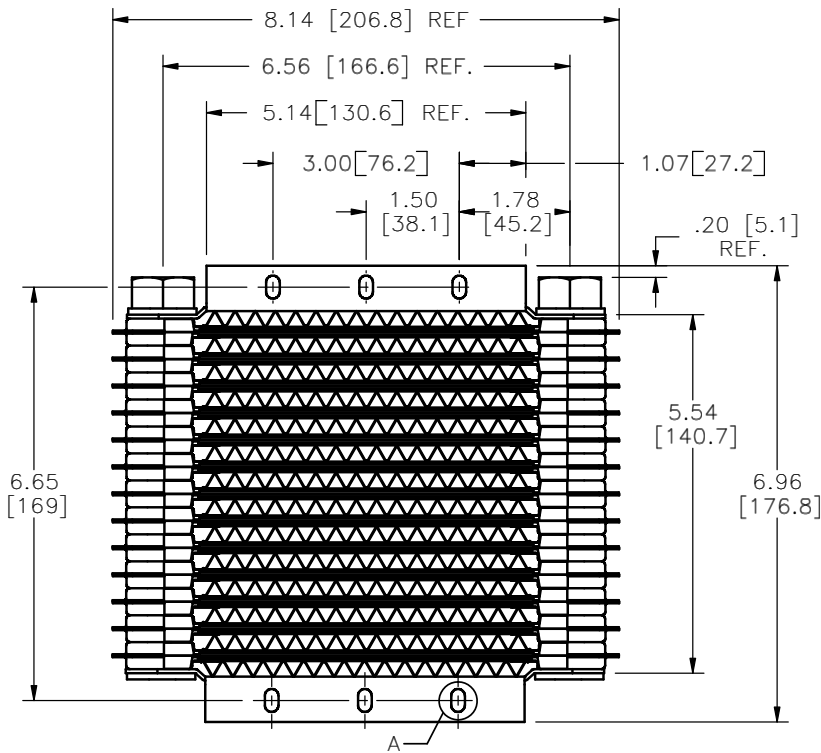

DRY WEIGHT: 3.0 LBS.

FAA-PMA AIRCRAFT ELIGIBILITY:

**Pilatus Britten-Norman: BN-2A, BN-2B
Pitts Aerobatics-Pitts S2B**

REF. HARRISON P/N: 8534108

**3315 Haseley Drive
Niagara Falls, New York USA 14304
(716) 297-0652 Phone
(716) 297-2550 Fax
www.niagarathermal.com
formerly known as THE NDM/KINTEX Co.**

FAA-PMA ELIGIBILITY APPLICATION LIST NIAGARA DEVELOPMENT AND MFG. CO.									
DATE ISSUED: 3/31/98		PAGE: 3 OF 7		F - 0083		9	10/1/99		
						8	9/10/99		
						7	3/31/98		
						LEVEL	DATE	LEVEL	DATE
REVISION									
S U P	REV.		NDM PART NO.	NDM MODEL NO.	HARRISON PART NO.	HARRISON MODEL NO.	NDM TEST REPORT	PMA AIRCRAFT ELIGIBILITY	
	DWG	BM							
2	3	B	20006A	AOC09HG06-01	8534108	AP13AU06-01	QTR-19	Pilatus Britten-Norman BN-2A, BN-2B Pitts Aerobatics-Pitts S2B	
10	3	B	20009A	AOC18HG06-01	8533718	AP18AU06-01	QTR-18	Camarillo Aircraft Service COMMANDER 114 114A (TC A12S0)	
2	2	H	20010A	AOC16HG08-01	8535311	AP16AN08-01	QTR-5	Piper PA-31, PA-31-325, PA-31-350, PA-32RT-300T, PA-32-301T, PA-32R-301T, PA-31-325. Colemill Enterprises PA-31, PA-31-325, PA-31-350	
7	2	H	20010A	AOC16HG08-01	8535311	AP16AN08-01	QTR-5	Air America Cessna P210N STL-SA2568NM	
2	1	B	20012A	AOC09HG13-01	8537831	AP09AN13-06	QTR-4	Piper-PA31	
F-0083 03/31/98									