

NIAGARA THERMAL PRODUCTS, LLC

dba The NDM/Kintex Co.

AIRCRAFT OIL COOLER P/N: 20003A

This Oil Cooler features lightweight vacuum brazed aluminum construction providing reliable service, efficient heat transfer and low pressure drop. All units have FAA-PMA and are proof pressure tested at 400 psig and leak tested at 100 psig. Corrosion protection is provided by MIL-C-5541 Class 1A chromicoat.

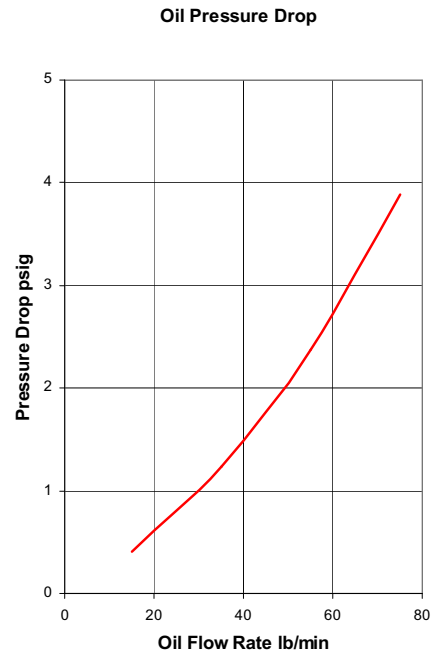
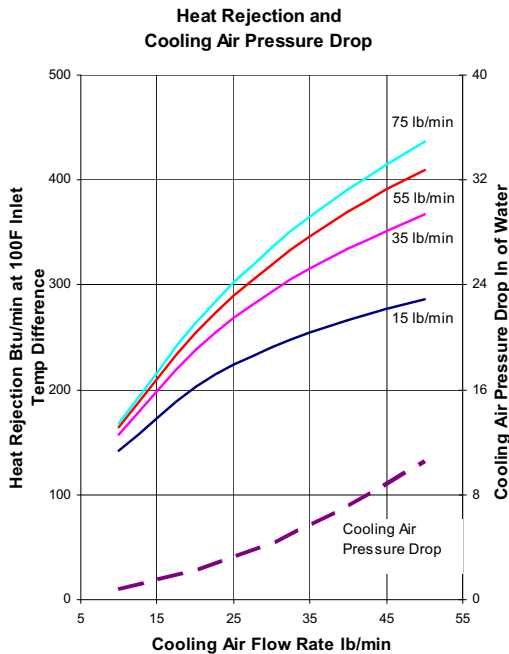
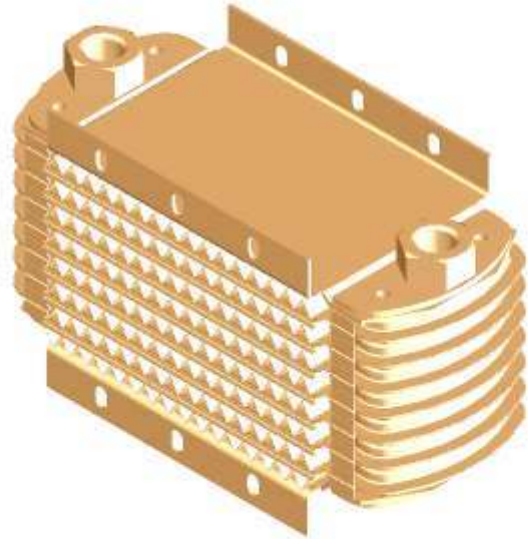

3315 Haseley Drive
Niagara Falls, New York USA 14304
(716) 297-0652 phone
(716) 297-2550 fax
www.ndm-heatexchangers.com

NIAGARA THERMAL PRODUCTS, LLC

dba The NDM/Kintex Co.

AIRCRAFT OIL COOLER P/N: 20003A

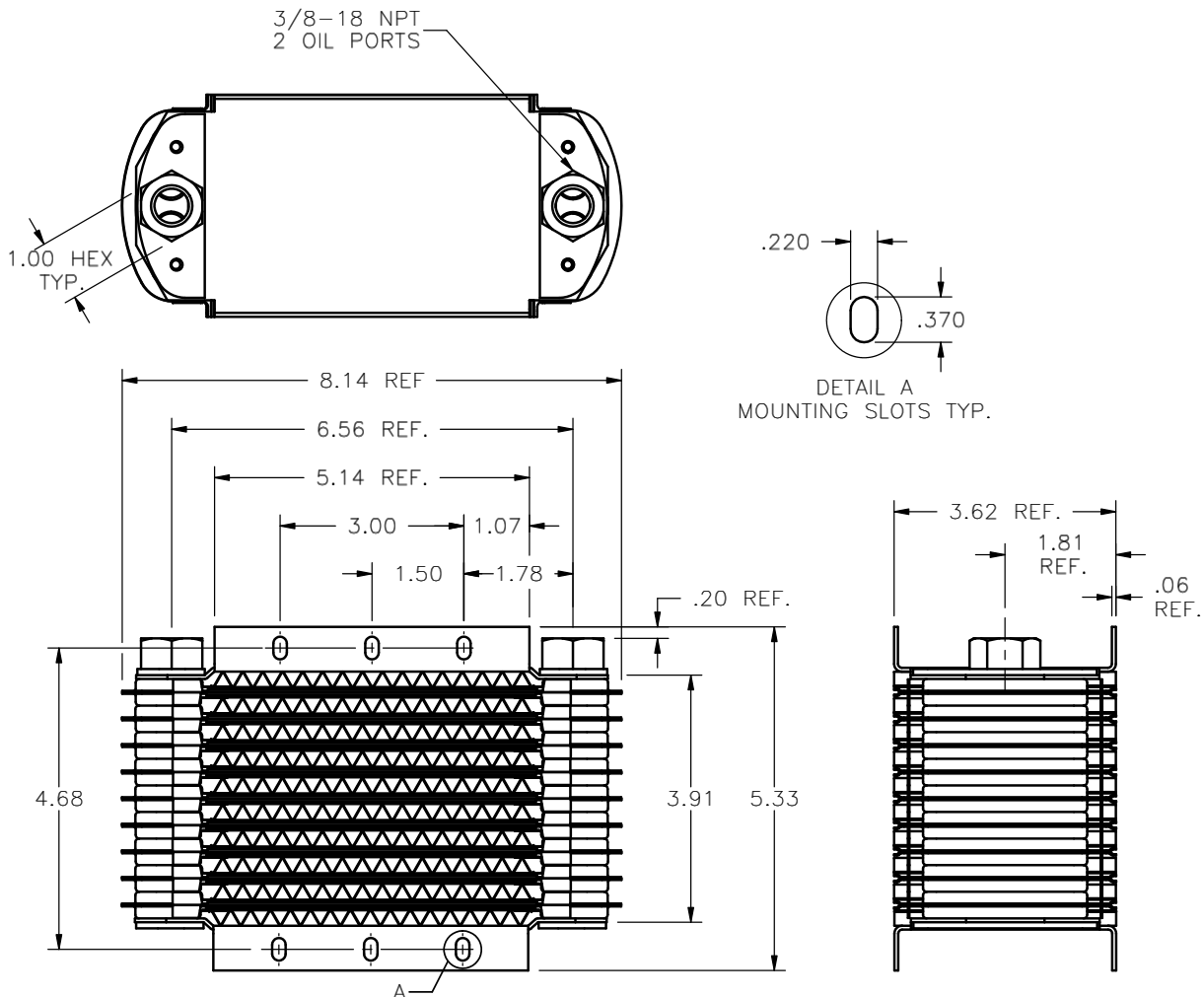

DRY WEIGHT: 2.4 LBS.

FAA-PMA AIRCRAFT ELIGIBILITY:

Maule Aircraft: MS-235C, M6-235

**Piper Aircraft: PA28-236, PA32-301, PA-16, PA-18S, PA-18"105", PA-18S"105-18A,
PA-18"125", PA-18S"125", PA-18AS"125", PA-18"135", PA-18S"135"
PA-18AS"135", PA-18"150", PA-18A"150", PA-18S"150", PA-18AS"150"
PA-19, PA-19S (T.C. 1A2)
PA-18, PA-18A, PA-18S, PA18"105" Special, PA-18"125" (Army L-21A),
PA-18S"125", PA-18AS"125", PA-18"135" (Army L-21B), PA-18A"135"
PA-18S"135", PA-18AS"135", PA-18"150", PA-18A"150", PA-18S150"
PA-18AS"150", PA-19 (Army L-18C, PA-19S (T.C. 1A2)**

REF. HARRISON P/N: 8529245

3315 Haseley Drive
Niagara Falls, New York USA 14304
(716) 297-0652 Phone
(716) 297-2550 Fax
www.ndm-heatexchangers.com