

# SUPERMAX® RIVETS - NOMINAL DIAMETER

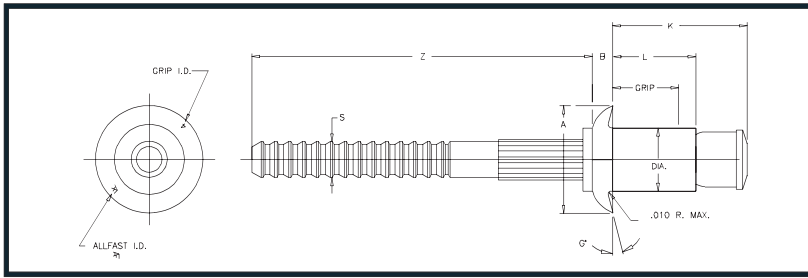

Part Number Example:

**AF9223 04 -02**

Basic Part Number  
 Nom. Diameter (1/32")  
 Maximum Grip (1/16")

GRIP LIMITS		GRIP DASH NO.	-4 DIA.		-5 DIA.		-6 DIA.	
MIN.	MAX.		L REF.	K MAX.	L REF.	K MAX.	L REF.	K MAX.
NOTE1	0.062	-01	0.140	0.38	0.187	0.41	0.219	0.47
0.063	0.125	-02	0.200	0.45	0.230	0.47	0.262	0.51
0.126	0.187	-03	0.263	0.51	0.293	0.53	0.325	0.57
0.188	0.250	-04	0.325	0.57	0.355	0.59	0.387	0.64
0.251	0.312	-05	0.388	0.63	0.418	0.65	0.450	0.70
0.313	0.375	-06	0.450	0.70	0.480	0.72	0.512	0.76
0.376	0.437	-07	0.513	0.76	0.543	0.77	0.575	0.82
0.438	0.500	-08	0.575	0.82	0.605	0.84	0.637	0.88
0.501	0.562	-09	0.638	0.88	0.668	0.90	0.700	0.95
0.563	0.625	-10			0.730	0.96	0.762	1.01
0.626	0.687	-11			0.793	1.02	0.825	1.07
0.688	0.750	-12					0.887	1.13

DIA. DASH NO.	DIA. +.003 - .001	A DIA. +/- .010	B +/- .005	S DIA. REF.	Z MIN.	HOLE LIMITS	DRILL SIZE NO.	G MAX. DEGREES
-4	0.126	0.250	0.059	0.071	0.87	.129 - .132	30	8
-5	0.157	0.312	0.072	0.089	0.94	.160 - .164	20	8
-6	0.189	0.375	0.085	0.108	0.94	.192 - .196	10	8

RIVET NO.	MATERIAL				FINISH			
	SLEEVE	STEM	LOCK RING	BULB FORMER	SLEEVE	STEM	LOCK RING	BULB FORMER
AF9223	5056 ALUM ALLOY QQ-A-430	15-7PH CRES AMS 5657	A-286 CRES AMS 5731	7050 ALUM ALLOY QQ-A-430	MIL-C-5541 PLAIN COLOR	PASSIVATE AMS 2700	PASSIVATE AMS 2700	MIL-C-5541

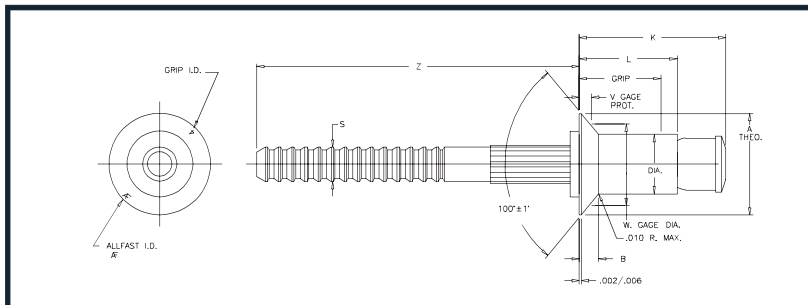

NOTES: 1

DIA. DASH NO.	MIN. GRIP	
	CSK	UNIV
-4	0.063	0.025
-5	0.065	0.031
-6	0.080	0.037

GRIP LIMITS		GRIP DASH NO.	-4 DIA.		-5 DIA.		-6 DIA.	
MIN.	MAX.		L REF.	K MAX.	L REF.	K MAX.	L REF.	K MAX.
NOTE1	0.125	-02	0.200	0.45	0.230	0.47	0.262	0.51
0.126	0.187	-03	0.263	0.51	0.293	0.53	0.325	0.57
0.188	0.250	-04	0.325	0.57	0.355	0.59	0.387	0.64
0.251	0.312	-05	0.388	0.63	0.418	0.65	0.450	0.70
0.313	0.375	-06	0.450	0.70	0.480	0.72	0.512	0.76
0.376	0.437	-07	0.513	0.76	0.543	0.77	0.575	0.82
0.438	0.500	-08	0.575	0.82	0.605	0.84	0.637	0.88
0.501	0.562	-09	0.638	0.88	0.668	0.90	0.700	0.95
0.563	0.625	-10			0.730	0.96	0.762	1.01
0.626	0.687	-11			0.793	1.02	0.825	1.07

DIA. DASH NO.	DIA. +.003 - .001	A DIA. +/- .004	B REF.	S DIA. REF.	Z MIN.	HOLE LIMITS	V +/- .0015	W +/- .0001
-4	0.126	0.225	0.042	0.071	0.87	.129 - .132	.0170	0.1840
-5	0.157	0.286	0.055	0.089	0.94	.160 - .164	.0215	0.2340
-6	0.189	0.353	0.070	0.108	0.94	.192 - .196	.0285	0.2840

RIVET NO.	MATERIAL				FINISH			
	SLEEVE	STEM	LOCK RING	BULB FORMER	SLEEVE	STEM	LOCK RING	BULB FORMER
AF9222	5056 ALUM ALLOY QQ-A-430	15-7PH CRES AMS 5657	A-286 CRES AMS 5731	7050 ALUM ALLOY QQ-A-430	MIL-C-5541 PLAIN COLOR	PASSIVATE AMS 2700	PASSIVATE AMS 2700	MIL-C-5541