

ALLMAX® BULB RIVETS

UNIVERSAL HEAD, LOCKED SPINDLE - NOMINAL DIAMETER

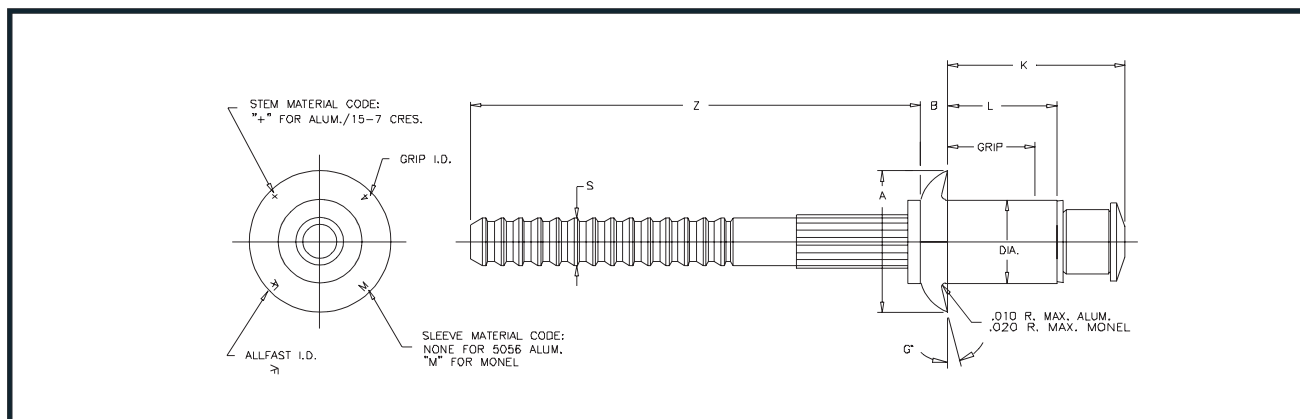

DIA. DASH NO.	DIA. +.003 - .001	A DIA. +/- .004	B REF.	S DIA. REF.	Z MIN.	HOLE LIMITS	DRILL SIZE NO.	G MAX. DEGREES
-4	0.126	0.250	0.059	0.071	0.87	.129 - .132	30	8
-5	0.157	0.312	0.072	0.089	0.94	.160 - .164	20	8
-6	0.189	0.375	0.085	0.108	0.94	.192 - .196	10	8

GRIP LIMITS		GRIP DASH NO.	-4 DIA.		-5 DIA.		-6 DIA.		
MIN.	MAX.		L +.000	-.030	K MAX.	L +.000	-.030	K MAX.	
NOTE 1	0.062	-01	.161		0.38	0.187	0.41	0.219	0.47
0.063	0.125	-02	.224		0.45	0.230	0.47	0.262	0.51
0.126	0.187	-03	.287		0.51	0.293	0.53	0.325	0.57
0.188	0.250	-04	.349		0.57	0.355	0.59	0.387	0.64
0.251	0.312	-05	.412		0.63	0.418	0.65	0.450	0.70
0.313	0.375	-06	.474		0.70	0.480	0.72	0.512	0.76
0.376	0.437	-07	.537		0.76	0.543	0.77	0.575	0.82
0.438	0.500	-08	.599		0.82	0.605	0.84	0.637	0.88
0.501	0.562	-09	.662		0.88	0.668	0.90	0.700	0.95
0.563	0.625	-10				0.730	0.96	0.762	1.01
0.626	0.687	-11				0.793	1.02	0.825	1.07
0.688	0.750	-12						0.887	1.13

RIVET NO.	SLEEVE	MATERIAL STEM	LOCK RING	SLEEVE	FINISH STEM	LOCK RING
AF3213 NAS9301B	5056 ALUM. ALLOY	8740 ALLOY STEEL	A-286 CRES AMS 5731	MIL-C-5541 PLAIN COLOR	CAD PLATE QQ-P-416 TYPE II CLASS II	PASSIVATE AMS 2700
AF3223 NAS9301E	5056 ALUM. ALLOY	PH 15-7 MO CRES	A-286 CRES AMS 5731	MIL-C-5541 PLAIN COLOR	AMS 2700	PASSIVATE AMS 2700
AF3523 NAS9307M	MONEL QQ-N-281	PH 15-7 MO CRES	A-286 CRES AMS 5731	NONE	AMS 2700	PASSIVATE AMS 2700
AF3523R	MONEL QQ-N-281	PH 15-7 MO CRES	A-286 CRES AMS 5731	NONE	AMS 2700	PASSIVATE AMS 2700
AF3523P NAS9307MN	MONEL QQ-N-281	PH 15-7 MO CRES	A-286 CRES AMS 5731	ALUM. COAT NAS 4006	AMS 2700	PASSIVATE AMS 2700
AF3523F NAS9307ML	MONEL QQ-N-281	PH 15-7 MO CRES	A-286 CRES AMS 5731	MIL-C-83488 ALUM. COAT	AMS 2700	PASSIVATE AMS 2700

NOTES: 1

DIA. DASH NO.	MIN. GRIP
-4	0.025
-5	0.031
-6	0.037

Part Number Example:

AF3213 (X) X -X S

Basic Part Number _____
 Finish Code _____
 Nom. Diameter (1/32") _____
 Grip Length (1/16") _____
 Indicates Strip Load _____

ALLMAX® NOMINAL DIAMETERS